

SUBCOURSE
IT0338

EDITION
A

US ARMY INTELLIGENCE CENTER

**INTRODUCTION TO LOGICAL
TROUBLESHOOTING**

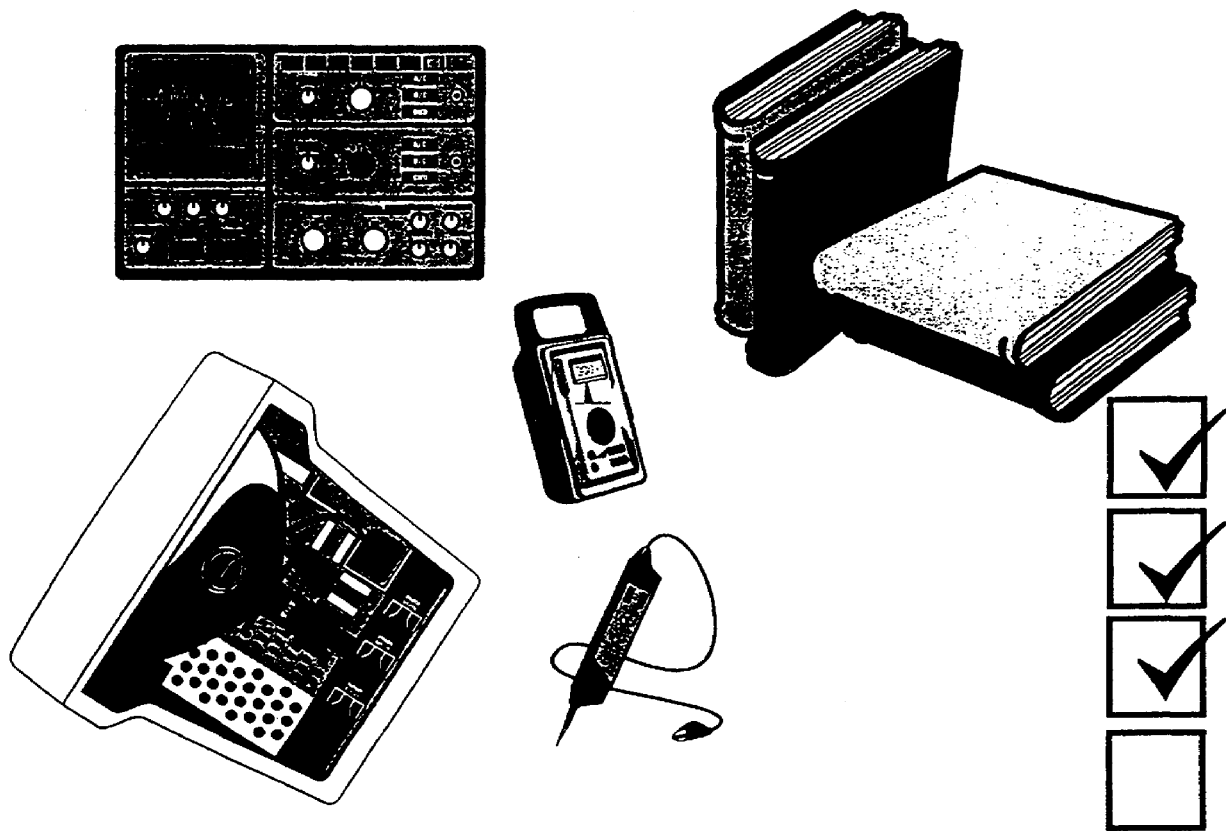

THE ARMY INSTITUTE FOR PROFESSIONAL DEVELOPMENT
ARMY CORRESPONDENCE COURSE PROGRAM

**A
I
P
D**

**READINESS/
PROFESSIONALISM**



**THRU
GROWTH**

INTRODUCTION TO LOGICAL TROUBLESHOOTING

Subcourse Number IT0338

EDITION A

US ARMY INTELLIGENCE CENTER
FORT HUACHUCA, AZ 85613-6000

2 Credit Hours

Edition Date: May 1996

SUBCOURSE OVERVIEW

This subcourse is designed to teach you the concepts of troubleshooting electronic equipment.

This subcourse replaces SA 0708.

There are no prerequisites for this subcourse.

TERMINAL LEARNING OBJECTIVE:

- TASK: You will be able to do each of the following:
- Select the four requirements for good troubleshooting.
 - Determine the two major questions in troubleshooting.
 - Identify the steps necessary to establish initial brackets when troubleshooting.
 - Label examples of and define signal flowpaths.
 - Select the correct order of checks which constitutes an "information funnel."
 - Determine the best procedure for troubleshooting multiple malfunctions in an electronic circuit.
- CONDITION: Given correct and incorrect statements and definitions in this subcourse
- STANDARD: To demonstrate competency of this task, you must achieve a minimum of 70 percent on the subcourse examination.

TABLE OF CONTENTS

Section	Page
Subcourse Overview	i
Lesson	1-1

LESSON

INTRODUCTION TO LOGICAL TROUBLESHOOTING

CRITICAL TASK: NONE

OVERVIEW

LESSON DESCRIPTION:

Upon completion of this lesson you will understand and be able to identify the concepts of troubleshooting electronic equipment.

TERMINAL LEARNING OBJECTIVE:

TASK: Select the four requirements for good troubleshooting, determine the two major questions in troubleshooting, identify the steps necessary to establish initial brackets when troubleshooting, label examples of and define signal flowpaths, select the correct order of checks which constitutes an "information funnel," and determine the best procedure for troubleshooting multiple malfunctions in an electronic circuit.

CONDITION: Given the information provided in this subcourse.

STANDARD: To demonstrate competency of this task, you must achieve a minimum of 70 percent on the subcourse examination.

1. There are four requirements for good troubleshooting. A technician must have a knowledge of the system operation, i.e., a communications system, a fire-control system, or a complete weapons system. He must also have a knowledge of the use of test equipment. Without the effective use of test equipment, a technician will waste valuable time. The effective use of technical manuals and other references is also an important requirement for good troubleshooting. Every system used today has many manuals which explain the operation of the system. These are invaluable aids to the technician. The most important requirement for good troubleshooting, however, is the logical analysis of information obtained from the malfunctioning system. The symptoms are available, but it is up to the technician to obtain them quickly, to interpret them rapidly and correctly so that he can repair the system efficiently.

2. Many technicians attempt to troubleshoot malfunctioning systems, but they are unsuccessful or only partially successful. There are not magical methods available for becoming a good troubleshooter; however, there are good and bad, difficult and easy methods. There are four requirements, however, which every technician must be aware of if he is to become a good troubleshooter and utilize the good and easy methods.

List the four requirements for good troubleshooting in the space provided below:

(1) _____

(2) _____

(3) _____

(4) _____

IT0338

1-2

Answers for frame 2:

- (1) detailed knowledge of system operation.
- (2) knowledge of use of test equipment.
- (3) effective use of technical manuals.
- (4) logical analysis of information gained from malfunctioning system.

3. Every technician should constantly strive to improve his knowledge of the systems he works with, his use of test equipment, and his effective use of technical manuals. However, the logical analysis of information gained from a malfunctioning system requires first that he consider two important questions:

- (1) Where to troubleshoot?
- (2) What to troubleshoot?

Most modern electronic systems consist of many circuits and components. To approach a malfunctioning system blindly, hoping to stumble on the trouble, only wastes time and creates problems. Normally, only one portion of a system goes bad at once. By isolating the bad portion, the work of the technician can be made much easier. He must know where to troubleshoot. There are three steps which can help him isolate the bad portion of a system from the rest of it. First, all the symptoms must be found. Next, the abnormal signal paths (circuits or components showing faulty characteristics) must be determined. Last of all, the troubleshooter must establish brackets, either mentally or on a block diagram of the system, to isolate the malfunctioning portion of the system from the normal portion. These three steps are used to establish "initial brackets." Initial brackets help the troubleshooter avoid making pointless checks later on. They get him started on the right track.

3. (Continued)

State the two major questions in troubleshooting.

(1) _____

(2) _____

Three steps are necessary to establish initial brackets when troubleshooting. Arrange the steps listed below in their correct order by placing the correct number 1,2,3) in the parentheses.

() Locate the abnormal signal paths (circuits).

() Find all the symptoms.

() Establish the brackets.

Answers for frame 3:

(1) Where to troubleshoot?

(2) What to troubleshoot?

Correct order is 2, 1, 3.

4. What is meant by establishing brackets? Let's take a typical problem and establish initial brackets. Figure 1-1 shows a block diagram of a combination AM/FM radio and a phonograph. The AM and the phonograph work perfectly, but when the FM is selected, only a quiet hum is heard from the speaker. The first bracket would be placed on the block diagram at the point where the first indication of an abnormal signal path exists. The second bracket would be placed where the normal signal path exists -- so that ALL the affected circuits (or components) are included within the brackets.

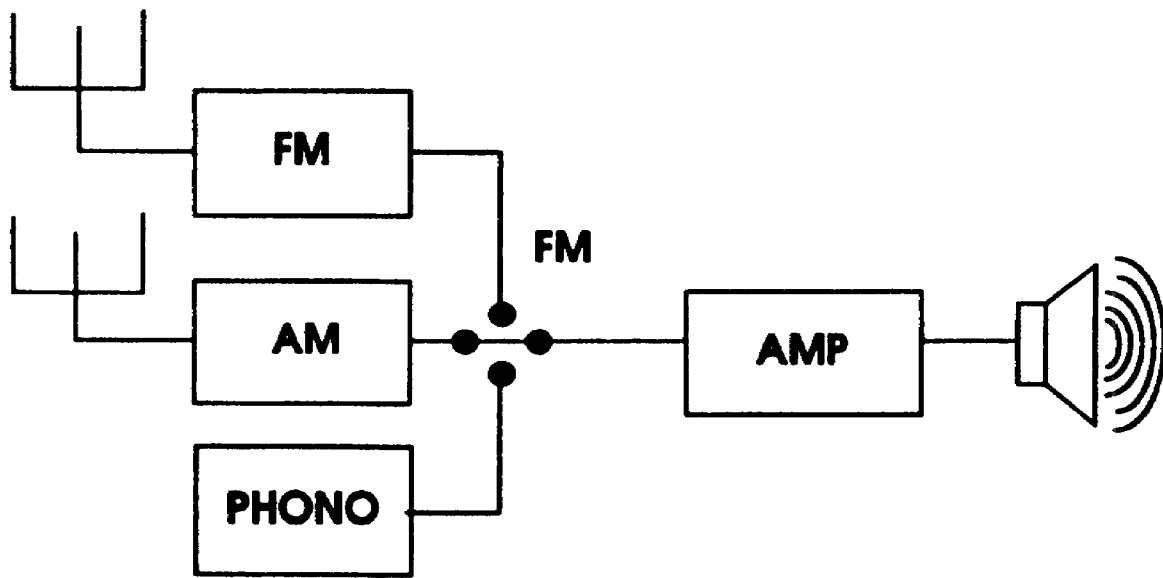
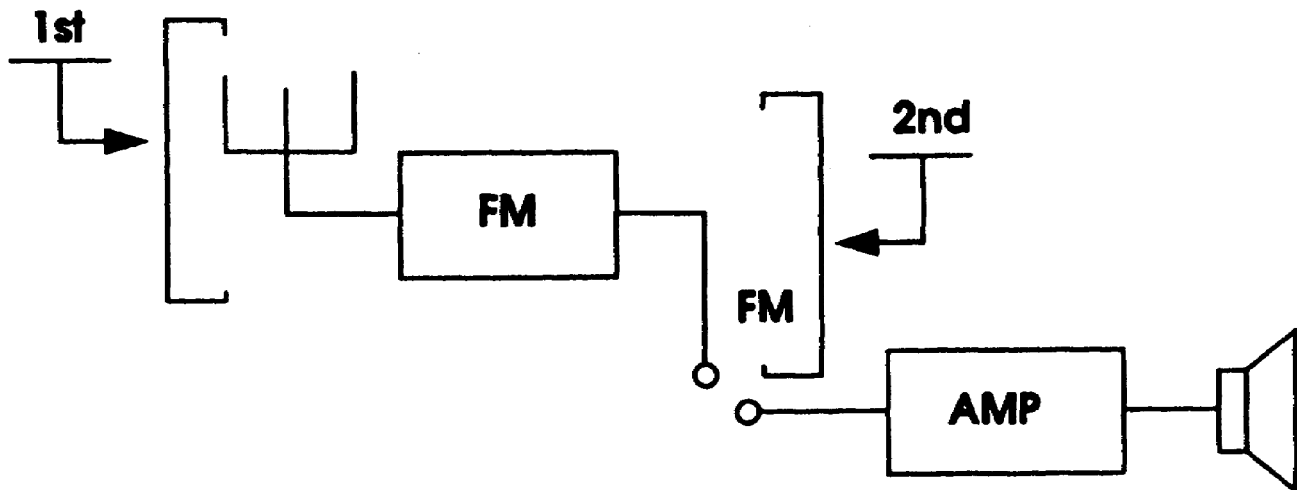

Figure 1-1.

Remember, to establish initial brackets: find all the symptoms, locate the abnormal signal paths, and then establish the brackets. On Figure 1-1, establish the brackets for the trouble described above.

Answer for frame 4: The first bracket should have been placed at the left of the FM antenna. The second bracket should have been placed to the right of the selector switch so that the antenna, the FM block, and the FM switch were included between the initial brackets.



5. From the list below, select four requirements for good troubleshooting.
(Circle your choices.)

- a. Knowledge of the use of test equipment
- b. Knowledge of the system operators capabilities
- c. Effective use of technical manuals
- d. Effective use of spare materials
- e. Logical analysis of information obtained from malfunctioning system
- f. Detailed knowledge of all previous troubles
- g. Detailed knowledge of system operation

Answers for frame 5: a, c, e, g

6. Establishing brackets helps the technician avoid pointless checks. There are three types of pointless checks which should be avoided: irrelevant checks, redundant checks, and premature checks. An irrelevant check is a check outside the brackets; it is unimportant and has no relation to the suspected trouble. A redundant check is a check which has been made already; it is time-consuming and gives no new information. A premature check is a check which does not reveal anything because enough other information is not known; it would have been done later.

A check which has already been made is called a _____ check.

A check outside the brackets is called an _____ check.

A check made too soon which should have been made later is a _____ check.

Answers for frame 6: redundant, irrelevant, premature

7. Taking time to establish initial brackets is important because it ensures getting started on the right track. The first step in establishing initial brackets is to find all the symptoms. Most of these can be observed by checking the "front panel" -- the operating controls for the complete system. Whether it is a simple communications receiver or a complicated bomb-director system, by checking for the proper functions of each operation control the troubleshooter can narrow down the possibilities and choices he must make. Once he has found all the symptoms, he can go to a schematic or a block diagram and note the affected signal paths or circuits. He must be sure to include every stage and component which is in some way affected by the trouble. Once he has done this, he is ready to establish his initial brackets. They may include the whole system, or they may include only a small portion of the system. When these have been established, the trouble area has been determined. The troubleshooter can avoid making pointless checks by checking within the brackets, by avoiding redundant checks and premature checks. Each check made should shift one or the other bracket closer to the trouble until only the exact trouble remains.

Match the following terms with their definitions by placing the correct letter in each blank.

- | | | |
|---------------------------|-----|--|
| a. Premature check | ___ | First step to establish initial brackets |
| | ___ | Check outside the brackets |
| b. Redundant check | ___ | Check not usable for lack of information |
| | ___ | Last step to establish initial brackets |
| c. Establish the brackets | ___ | Check which is repeated-not necessary |
| | ___ | Second step is to establish initial brackets |
| d. Find the symptoms | ___ | Two major questions in troubleshooting |
| e. Irrelevant check | | |
| f. Determine the affected | | |
| | | stages or circuits |
| g. Where and what to | | |
| | | check? |

\

1-9

IT0338

Answers for frame 7: (From top to bottom) d, e, a, c, b, f, g

8. The following questions will check your understanding of some of the Information presented this far. Answer them to the best of your ability and check your answers at the top of page 1-10.

a. State the two major questions in troubleshooting.

b. Three steps are necessary to establish initial brackets when troubleshooting. Arrange the steps listed below in their correct order by placing the correct number (1, 2, 3) in the parentheses.

() Locate the abnormal signal paths

() Find all the symptoms

() Establish the brackets

c. Define the following types of pointless checks:

Irrelevant check-

Redundant check-

Premature check-

- Answers for frame 8:
- a. Where to troubleshoot? What to troubleshoot?
 - b. 2, 1, 3
 - c. Irrelevant check- check outside the brackets
 Redundant check-repeat check which tells no new information
 Premature check-check which tells nothing until other checks are made

9. Thus far, only initial brackets have been established for a troubled area. Once initial brackets have been established, the troubleshooter must decide where to check next. This will depend mainly upon the type of signal flow path he is troubleshooting. There are five types of signal flow paths and five general rules to follow when troubleshooting each of them. The first type of signal flow path is the simplest of them all - the LINEAR type.

As shown in figure 1-2, the linear signal flow path has only one path for the signal.



Figure 1-2.

When troubleshooting a linear signal flow path, always make the first check at or just before the midpoint of the path enclosed within the brackets.

Assume that the initial brackets have been established as shown in figure 1-3.

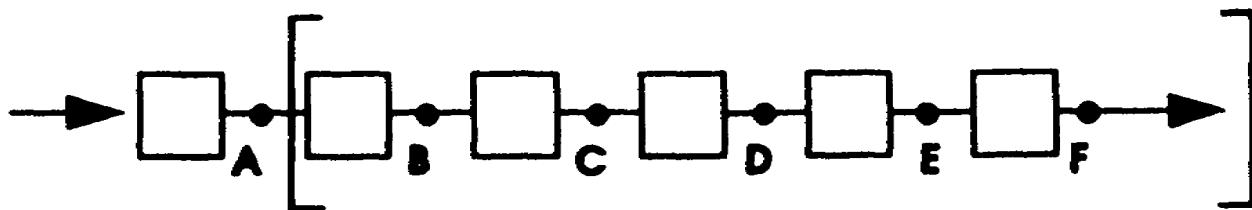

Figure 1-3.

The first check would be made at point_____.

Answer for frame 9: Point D (the midpoint of the brackets)

10. When troubleshooting a linear signal flow path, check at or just before the midpoint of the trouble brackets. If the check is good, move the first (left) bracket to that point and repeat the process. If the check is bad, move the last (right) bracket to that point and repeat the process. In either case, the trouble area is being narrowed down by half after each check. (This is called the "half-split" principle.)

Figure 1-4 shows a linear signal flow path with initial brackets established. Assume that the first check shows normal at that point. Which bracket would be moved to that point, and where would the next check be made?

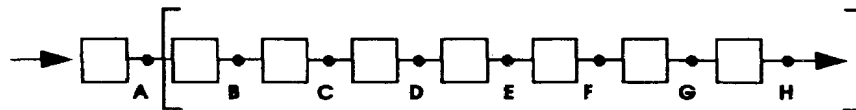

Figure 1-4.

Move the (first / second) bracket to the midpoint. The next check would be made at point_____.

Answer for frame 10: Move the first bracket to point E and make the next check at point G.

11. Figure 1-5, below, shows a basic CONVERGENT type of signal flow path. A convergent signal path exists when there is more than one input to a stage (block). Some types of convergent stages require all the inputs before there is an output, while other types require only one input to produce an output. If there is no output from a convergent stage, each or every input must be checked.

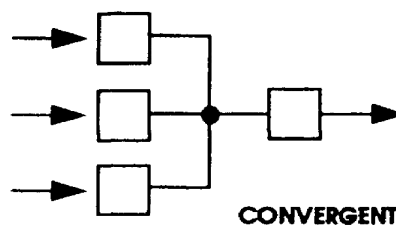

Figure 1-5.

11. (Continued)

In a sense, some linear signal flow paths could also be considered to be convergent signal flow paths. For instance, the IF amplifiers in a standard communications receiver are connected in series, but power must be supplied to each amplifier from another source. The power input could be considered as one of the inputs to the amplifiers, along with the various signal inputs (as shown in figure 1-6).

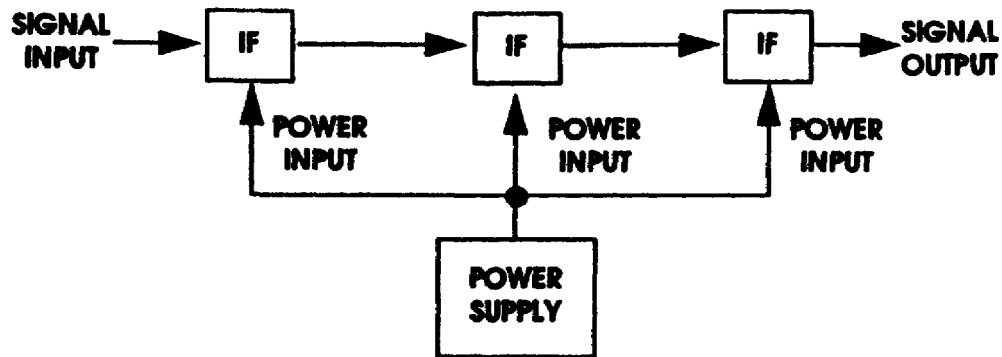
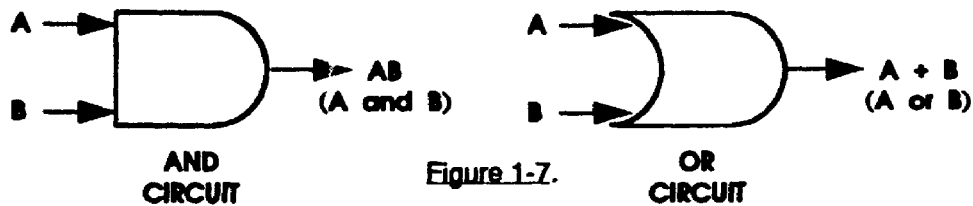

Figure 1-6.

Computers also use convergent circuits. Figure 1-7 shows an AND circuit, where all the inputs are required to produce an output, and it shows an OR circuit, where any or all of the inputs could produce an output. Simply stated, an input (or output) is considered a High (H) or (1); no input (or output) is considered a Low (L) or (0).



The best way to check a convergent signal flow path when there is no output is to (choose one of the following)

- (1) check only one of the inputs.
- (2) check each or every input.
- (3) check all the preceding stages (blocks).

Answer for frame 11: (2) check each or every input

12. Just the opposite from a convergent type of signal flow path is the DIVERGENT type of signal flow path. Figure 1-8 shows a typical divergent type of signal flow path. The power distribution system in most electronic equipment is an excellent example of a divergent type of signal flow path (refer to figure 1-6, page 1-11). To check for the proper operation of a divergent stage, check any output for a normal indication.

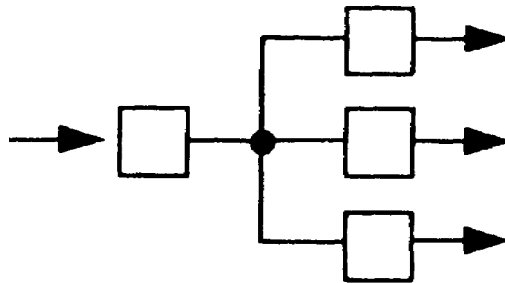

DIVERGENT
Figure 1-8.

The type of signal flow path which has one input and more than one output is called a _____type. To troubleshoot this type of signal flow path, a troubleshooter should check any _____for a normal indication.

Answers for frame 12: divergent, output

13. Label the types of signal flow paths shown below, and briefly state the general rule to follow when troubleshooting each of them.

	TYPE	RULE
a. 		
b. 		
c. 		

Answers for frame 13: a. linear - check at or Just before midpoint of brackets.
 b. convergent - check each or every input.
 c. divergent - check any output for normal indication.

14. There are two other types of signal flow paths which are found in many systems: switching and feedback. These are shown in figure 1-9.

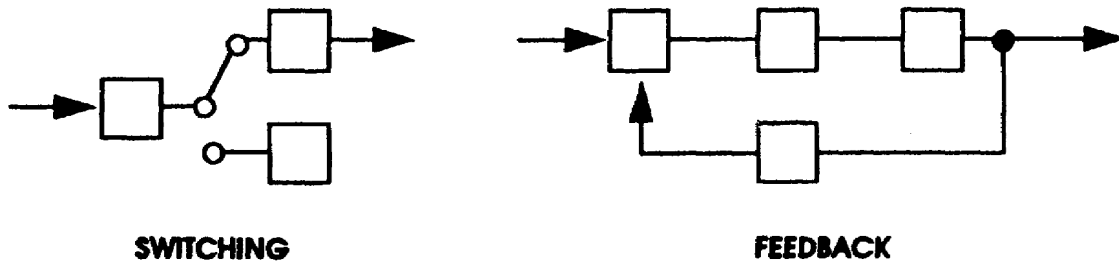

Figure 1- 9.

Switching circuits are common in all types of systems. To check this type of signal flow path, simply check to see which circuits are affected by changing the position of the switch. Feedback circuits are common in many types of communications, control, and computer systems. To check a feedback circuit, modify the feedback (change it by either completely disconnecting it or by changing its value with a control) while checking the output. There should be a noticeable indication in the output when the feedback is modified.

If a troubleshooter is checking to see which circuits are affected by a trouble, ("through the use of a switch") he is probably checking a _____ type of signal flow path. If he is checking a feedback type of signal flow path, he is modifying the _____ while checking the effect on the _____ .

Answers for frame 14: switching, feedback, output

15. Label the types of signal flow paths shown below and briefly state the general rule to follow when troubleshooting each of them.

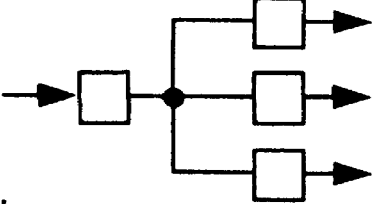
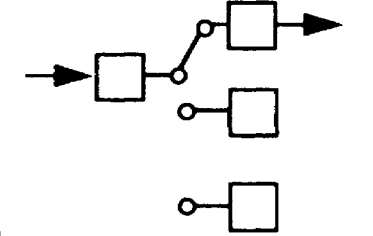
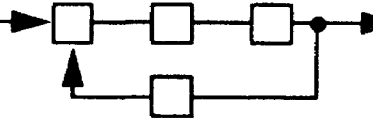
	TYPE	RULE
<p>a.</p> 		
<p>b.</p> 		
<p>c.</p> 		

Answers for frame 15: a. divergent - check any output for normal indications.
 b. switching - check to see which circuits are affected.
 c. feedback - check the output as you modify the feedback.

16. Most signal flow systems, whether they are communications systems, navigation systems, fire-control systems, or radar systems, consist of various combinations of these five basic signal flow paths. When troubleshooting a system, it is often necessary to combine the general rules, depending upon the portion of the system which is being checked. An entire system can be thought of as a large linear signal flow path. The initial brackets are established (mentally or physically) on a block diagram of the system, and then the first check is made at or near the

16. (Continued)

midpoint of the trouble brackets. Each additional check should eliminate as much of the system as possible, following closely the "half-split" principle. Convergent circuits can be checked by checking each or every input. Divergent circuits can be checked by checking any output. Switching circuits can be checked by seeing which circuits are affected by the trouble. Feedback circuits can be checked by modifying the feedback and checking the output. These are general rules to follow when troubleshooting any type of system, but they are logical and efficient, and very easily adapted to suit any situation.

17. The following questions will check your understanding of the information presented in frames 9 - 16. Answer them to the best of your ability and check your answers on page 1-16.

- a. Label each of the examples of signal flow paths shown, using the following names:

linear
convergent
divergent
switching
feedback

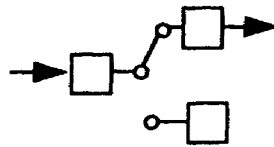

a. _____

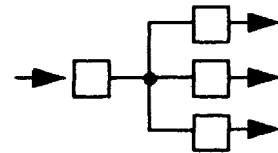

b. _____



c. _____

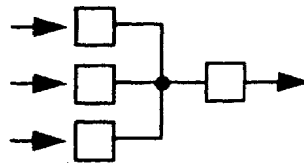

d. _____

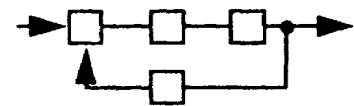

e. _____

17. (Continued)

- b. From the list of troubleshooting rules in column B, select the rule that applies to the type of signal flow path listed in column A. Place the number of each selection in blanks in column A.

	A	B
linear	_____	1. Check any output for a normal indication.
switching	_____	2. Check at or just before the midpoint of the brackets.
convergent	_____	3. Check all front panel indications.
feedback	_____	4. Check the output as you modify (change) one of the inputs.
divergent	_____	5. Check to see which circuits are affected.
		6. Check each or every input.

Answers for frame 17:a. 1. switching 2. divergent 3. linear
4. convergent 5. feedback

b. 2,5,6,4, 1

18. Knowing where to check is the first important step in troubleshooting; knowing what to check is the next consideration. Different types of checks have a different "usefulness," depending upon when each is used. The most general checks should be used first, and the most specific checks should be used last. This principle can be thought of as an "information funnel." The check which yields the most information is performed first; the one that is the most specific is performed last. In electronic troubleshooting, the order of checks according to their usefulness is: front panel, operational adjustments, waveforms, voltages, resistances, and part replacement. Notice that these go from general to specific.

Answers for frame 18:

1. Front panel.
2. Operational adjustments.
3. Wave Forms.
4. Voltages.
5. Resistances.
6. Part replacement.

18. (Continued).

List the types of checks used in electronic troubleshooting according to their usefulness.

(Check your answer at the bottom of Page 1-17.)

19. The two most general types of checks are front panel checks and operational adjustments. They can also be the most useful in getting started on the right track when troubleshooting. Front panel checking includes noting every aspect of the system's behavior. Turn it on; warm it up; notice any normal or abnormal indications or outputs. Next use each operational adjustment (volume control, channel selector, indicator control, fine adjustment, intensity and contrast control, etc.) and see what effect it may have on the malfunction. By then, the initial brackets can be established on the block diagram (mentally or physically). Waveform checks are the next most useful checks. Waveform checks provide a picture of the normal and abnormal functions in the system. They help narrow down the bracketed area to a stage or subcomponent. Voltage checks then provide more precise information in the suspected area. Resistance checks give detailed information about specific components. Last of all, when a part is replaced, the troubleshooter performs an operational check and learns whether he was right or wrong in his analysis of the malfunction.

19. (Continued)

Arrange the following list of troubleshooting checks in their correct order according to their usefulness. (Place numbers 1, 2, etc., in the parentheses.)

- () part replacement and operational check
- () voltage measurement
- () operational adjustments
- () resistance measurements
- () front panel observations
- () waveform observations

Answers for frame 19: 6, 4, 2, 5, 1, 3

20. Although there is an order of usefulness for electronic troubleshooting checks, there is no substitute for a detailed knowledge of the system, use of available technical manuals, knowledge of the use of test equipment, or a logical analysis of the information obtained from the malfunctioning system. The right combination of these four factors will enable every troubleshooter to be efficient and effective at his job. Experience is an important part of troubleshooting, but remembering the general rules can help even the experienced troubleshooter do a better job. Remember the information funnel when making checks:

1. FRONT PANEL OBSERVATION
2. OPERATIONAL ADJUSTMENTS
3. WAVEFORMS
4. VOLTAGES
5. RESISTANCE
6. PART RE-
PLACE-
MENT
AND OPERATIONAL CHECK

21. Sometimes, especially in electronic equipment, more than one problem will occur in the same system at the same time. This can be very distressing, but the situation can be overcome. The best method of troubleshooting more than one problem is to assume that only one problem exists, and troubleshoot it as one problem. Many times, by correcting one problem, the other is readily apparent and easily repaired.

Which of the following is the best method of troubleshooting more than one malfunction in an electronic system? (Circle the letter of your choice).

- a. Call in more than one troubleshooter.
- b. Replace the entire system with a better one.
- c. Try to find both problems, at the same time.
- d. Assume only one fault exists and troubleshoot that one first.
- e. Divide your time evenly and try to fix both problems.
- f. Ask your supervisor for an easier job and let him solve the problem.

Answer for frame 21: d.

22. Multiple problems occur in an electronic system; often one is the result of the other. By finding the first fault, the second one shows up too. Sometimes it is impossible to know what the second fault is until the first one is cleared up.

In your own words, state the best procedure for troubleshooting multiple malfunctions. _____

Answer for frame 22: Assume that only one fault exists and troubleshoot that one first. Then troubleshoot each remaining fault, using the logical troubleshooting procedures.

23. Listed below are different types of troubleshooting checks. Rearrange this list according to the order of usefulness of the checks.

waveforms

front panel

voltages

part replacement and operational check

resistances

operational adjustments

Answer for frame 23: Check at the bottom of page 1-17.

24. Besides the general rules for troubleshooting, there are a few general considerations which each troubleshooter must remember. In every situation, he must be sure to note all the symptoms (proper functioning and malfunctioning). Then he must use schematics and diagrams and apply his findings to establish his initial brackets. He must narrow down the possibilities by checking within the brackets, interpreting his results, and moving the brackets closer to each other. He must get the most out of each check, avoiding irrelevant checks, redundant checks, and premature checks. He must rely upon his knowledge of the system operation, his test equipment, technical manuals, and his logical analysis of the malfunctioning system. A consistent, logical method of troubleshooting will be efficient and effective; and by using these principles of troubleshooting, the troubleshooter will become more and more proficient as he gains experience.

25. State the best procedures for troubleshooting multiple malfunctions.

Answer for frame 25: Assume one trouble exists and find it first. Then troubleshoot the remaining faults.

26. In this program, you have learned the general principles of troubleshooting. Now you are ready to practice troubleshooting using these principles. Use of these principles will enable you to approach the task of troubleshooting a system in a sensible, logical manner. As you gain experience with particular systems, you will find that the job becomes easier, and you will work faster. The importance of the first few steps cannot be overemphasized! NOTE ALL THE SYMPTOMS, LOCATE ALL THE ABNORMAL SIGNAL PATHS, then ESTABLISH INITIAL BRACKETS. Begin checking within the brackets, trying to eliminate half the remaining system each time. Recognize the type of signal flow path involved and troubleshoot it accordingly. Perform the general checks first, and then perform the specific checks. Avoid irrelevant checks (outside the brackets), redundant checks (checks you have done already), and premature checks (checks which should be done later). One last point - use your head! Don't become bound by a method so much that you don't stop to think. These principles are guides which will enable you to become a proficient troubleshooter on complicated electronic systems, BUT the troubleshooting job is still up to YOU!!!

LESSON

PRACTICE EXERCISE

The following items will test your grasp of the material covered in this lesson. When you complete the exercise, check your answers with the answer key that follows. If you answer any item incorrectly, study again that part of the lesson which contains the portion involved.

1. From the list below, select what you consider to be the four requirements for good troubleshooting. (Circle the letters of your choice).

- a. Detailed knowledge of system operation.
- b. Knowledge of system operator's capability.
- c. Logical analysis of information gained from malfunctioning system.
- d. Knowledge of use of test equipment.
- e. Effective use of all spare materials.
- f. Effective use of technical manuals.

2. State the two major questions in troubleshooting.

- (A) _____

- (B) _____

3. Three steps are necessary to establish initial brackets when troubleshooting. Arrange the steps listed below in their correct order by placing the correct number (1, 2, 3) in the parentheses.

- () Locate the abnormal signal paths (circuits).
- () Find all the symptoms.
- () Establish the brackets.

4. Match the following terms with their definitions by placing the correct letter in each blank.

- a. Premature check _____ First step to establish initial brackets
- b. Redundant check _____ Check outside the brackets
- c. Establish the brackets _____ Check not usable for lack of information
- d. Find the symptoms _____ Last step to establish initial brackets
- e. Irrelevant check _____ Check which is repeated-not necessary
- f. Determine the affected stages or circuits _____ Second step to establish initial brackets
- g. Where and what to check? _____ Two major questions in troubleshooting.

5. What is the best way to check a convergent signal flow path when there is no output? (Choose one of the following)

- (A) Check only one of the inputs.
- (B) Check each or every input.
- (C) Check all the preceding states (blocks).

6. Label the types of signal flow paths shown below, and briefly state the general rule to follow when troubleshooting each of them, using the following names: linear, convergent, divergent, switching, feedback.

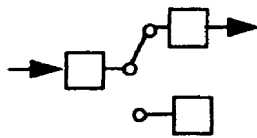

a. _____

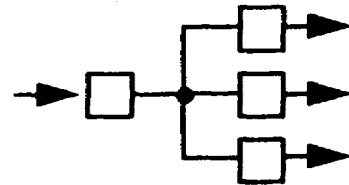

b. _____



c. _____

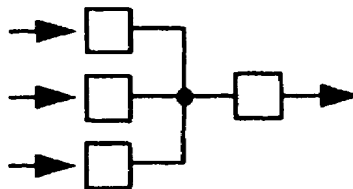

d. _____

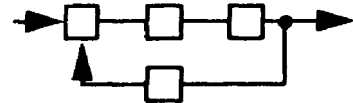

e. _____

7. List the types of checks used in electronic troubleshooting according to their usefulness.

8. Which of the following is the best method of troubleshooting more than one malfunction in an electronic system? (Circle the letter of your choice.)

- a. Call in more than one troubleshooter.
- b. Replace the entire system with a better one.
- c. Try to find all faults at the same time.
- d. Assume only one fault exists and troubleshoot that one first.
- e. Divide your time evenly and try to fix both faults.
- f. Ask your supervisor for an easier job and let him solve the problem.

LESSON

PRACTICE EXERCISE

ANSWER KEY AND FEEDBACK

<u>Item</u>	<u>Correct Answer and Feedback</u>
1.	a, c, d, f.
2. (A)	Where to troubleshoot?
(B)	What to troubleshoot?
3.	2, 1, 3.
4.	d, e, a, c, b, f, g.
5. (B)	Check each or every input
6. a.	switching -- check to see which circuits are affected.
b.	divergent -- check any output for normal indication.
c.	linear -- check at or Just before midpoint of brackets.
d.	convergent -- check each or every input.
e.	feedback -- check the output as you modify the feedback.

7. front panel
operational adjustments
waveforms
voltages
resistances
part replacement

8. d.

