

**U.S. ARMY MEDICAL DEPARTMENT CENTER AND SCHOOL
FORT SAM HOUSTON, TEXAS 78234-6100**

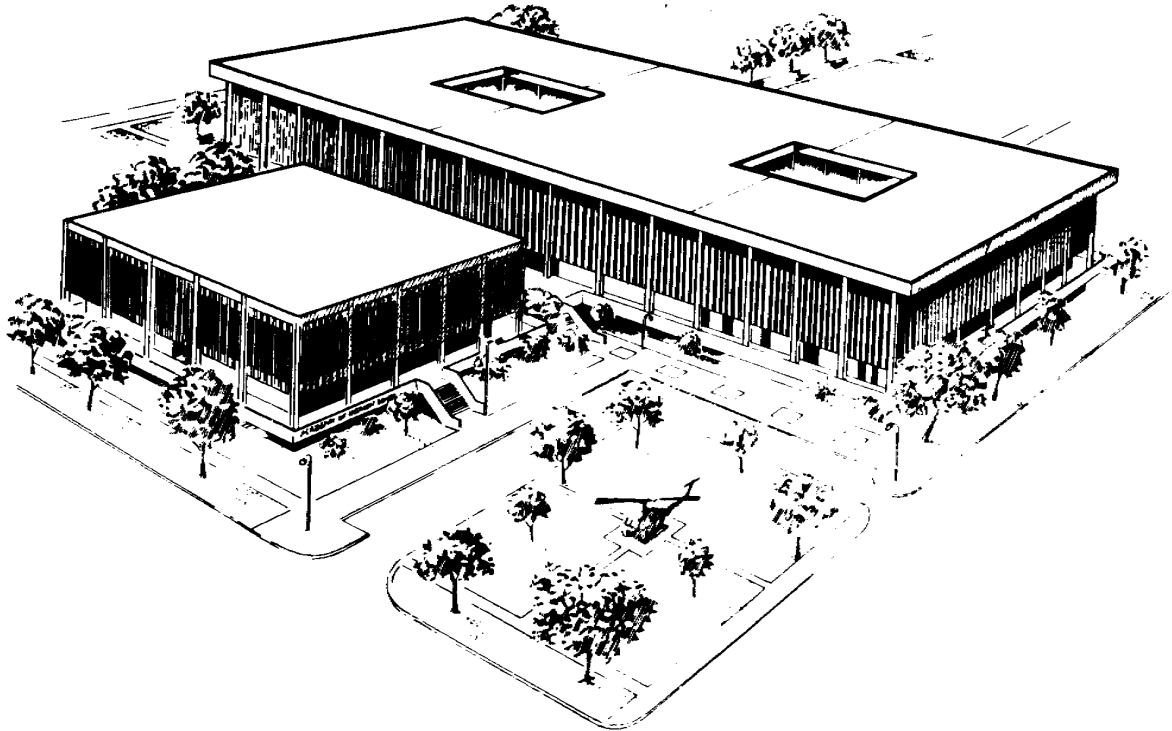

SOLID WASTE DISPOSAL

SUBCOURSE MD0162

EDITION 100

DEVELOPMENT

This subcourse is approved for resident and correspondence course instruction. It reflects the current thought of the Academy of Health Sciences and conforms to printed Department of the Army doctrine as closely as currently possible. Development and progress render such doctrine continuously subject to change.

When used in this publication, words such as "he," "him," "his," and "men" are intended to include both the masculine and feminine genders, unless specifically stated otherwise or when obvious in context.

The instructional systems specialist responsible for development of this edition was William H. Shade, DSN 471-8906 or commercial (210)221-8906; Academy of Health Sciences, Multimedia Development Branch, ATTN: MCCS-HLD, 2250 Stanley Road (Room 326), Fort Sam Houston, Texas 78234-6130.

The subject matter experts responsible for writing and content accuracy of this edition were from Preventive Medicine Division, DSN 471-8909 or commercial (210)221-8909; Commander, U.S. Army Medical Department Center and School, ATTN: MCCS-MP, Fort Sam Houston, Texas 78234-6100.

ADMINISTRATION

Students who desire credit hours for this correspondence subcourse must meet eligibility requirements and must enroll through the Nonresident Instruction Branch of the U.S. Army Medical Department Center and School (AMEDDC&S).

Application for enrollment should be made at the Internet website: <http://www.atrrs.army.mil>. You can access the course catalog in the upper right corner. Enter School Code 555 for medical correspondence courses. Copy down the course number and title. To apply for enrollment, return to the main ATRRS screen and scroll down the right side for ATRRS Channels. Click on SELF DEVELOPMENT to open the application and then follow the on screen instructions.

In general, eligible personnel include enlisted personnel of all components of the U.S. Army who hold an AMEDD MOS or MOS 18D. Officer personnel, members of other branches of the Armed Forces, and civilian employees will be considered eligible based upon their AOC, NEC, AFSC or Job Series which will verify job relevance. Applicants who wish to be considered for a waiver should submit justification to the Nonresident Instruction Branch at e-mail address: accp@amedd.army.mil.

For comments or questions regarding enrollment, student records, or shipments, contact the Nonresident Instruction Branch at DSN 471-5877, commercial (210) 221-5877, toll-free 1-800-344-2380; fax: 210-221-4012 or DSN 471-4012, e-mail accp@amedd.army.mil, or write to:

NONRESIDENT INSTRUCTION BRANCH
AMEDDC&S
ATTN: MCCS-HSN
2105 11TH STREET SUITE 4191
FORT SAM HOUSTON TX 78234-5064

TABLE OF CONTENTS

<u>Lesson</u>	<u>Paragraph</u>	<u>Page</u>
INTRODUCTION		ii
1 SOLID WASTE DISPOSAL AT FIXED INSTALLATION		
Section I Introduction	1-1-1-3	1-2
Section II. Refuse Collection and Disposal	1-4-1-10	1-10
Section III. Incineration	1-11-1-19	1-24
Section IV. Disposal of Wastes in Medical Treatment Facilities.....	1-20-1-24	1-28
Exercises		1-34
2 SOLID WASTE DISPOSAL IN THE FIELD		
Section I Introduction	2-1-2-3	2-2
Section II Solid Waste Disposal in the Field	2-4-2-11	2-3
Exercises		2-15

LIST OF ILLUSTRATIONS

<u>Figure</u>	<u>Page</u>
1-1 Front-loading compactor vehicle emptying a self-loading container.....	1-15
1-2 Side-loading compactor vehicle.....	1-15
1-3 Typical rear-loading compactor vehicle.....	1-16
1-4 Hoist-and-haul vehicle without container	1-16
1-5 Loading a roll-off container onto a tilt-frame truck.....	1-17
1-6 Diagram of sanitary landfill-trench method	1-21
1-7 Section of trench showing layers of compacted refuse.....	1-22
1-8 Notice, collection crews	1-26
2-1 Barrel incinerator	2-5
2-2 Inclined plane incinerator.....	2-6
2-3 Urinal soakage pit with pipes	2-8
2-4 Soakage trench with barrel filter grease trap	2-9
2-5 Baffle grease traps: (A) barrel type (B) box type.....	2-10
2-6 Barrel filter grease trap	2-11

**CORRESPONDENCE COURSE OF THE
U.S. ARMY MEDICAL DEPARTMENT CENTER AND SCHOOL**

SUBCOURSE MD0162

SOLID WASTE DISPOSAL

INTRODUCTION

In order to keep the environment clean and free of offensive sights and smells which cause a decrease in morale, to reduce harborage and food for insects and rodents, and to control communicable diseases which reduce manpower and work efficiency, the practice of sanitary waste disposal is necessary. The preventive medicine specialist has the task of spotting sanitary deficiencies and making the appropriate corrective recommendations. Because this is an important job, the basic aspects of it must be learned carefully.

This subcourse consists of two lessons and an examination as follows:

Lesson 1. Solid Waste Disposal at Fixed Installation.

Lesson 2. Solid Waste Disposal in the Field.

Examination

Credit Awarded:

Upon successful completion of this subcourse, you will be awarded 4 credit hours.

Materials Furnished:

Materials provided include this booklet, an examination answer sheet, and an envelope. Answer sheets are not provided for individual lessons in this subcourse because you are to grade your own lessons. Exercises and solutions for all lessons are contained in this booklet. *You must furnish a #2 pencil.*

Procedures for Subcourse Completion:

You are encouraged to complete the subcourse lesson by lesson. When you have completed all of the lessons to your satisfaction, fill out the examination answer sheet and mail it to the U.S. Army Medical Department Center and School along with the Student Comment Sheet in the envelope provided. *Be sure that your name, rank, social security number, and return address are on all correspondence sent to the U.S. Army Medical Department Center and School.* You will be notified by return mail of the examination results. Your grade on the exam will be your rating for the subcourse.

Study Suggestions:

Here are suggestions that may be helpful to you in completing this subcourse:

- Read and study each lesson carefully.
- Complete the subcourse lesson by lesson. After completing each lesson, work the exercises at the end of the lesson, marking your answers in this booklet.
- After completing each set of lesson exercises, compare your answers with those on the solution sheet, which follows the exercises. If you have answered an exercise incorrectly, check the reference cited after the answer on the solution sheet to determine why your response was not the correct one.
- As you successfully complete each lesson, go on to the next. When you have completed all of the lessons, complete the examination. Mark your answers in this booklet; then transfer your responses to the examination answer sheet using a #2 pencil.

Student Comment Sheet:

Be sure to provide us with your suggestions and criticisms by filling out the Student Comment Sheet (found at the back of this booklet) and returning it to us with your examination answer sheet. Please review this comment sheet before studying this subcourse. In this way, you will help us to improve the quality of this subcourse.

LESSON ASSIGNMENT

LESSON 1

Solid Waste Disposal at Fixed Installation.

TEXT ASSIGNMENT

Paragraphs 1-1 through 1-24.

LESSON OBJECTIVES

After completing this lesson, you should be able to:

- 1-1. Select the responsibilities of certain organizations in the command structure.
- 1-2. Select the types of solid wastes.
- 1-3. Select the responsibilities of certain personnel in the collection of refuse.
- 1-4. Select the essentials of a properly operated solid waste collection program.
- 1-5. Select the proper procedures for refuse collection.
- 1-6. Select the correct site considerations, operational techniques, and advantages of sanitary landfills.
- 1-7. Select the correct procedures for recycling and incineration.
- 1-8. Select the proper safety measures for sanitary landfills and incineration.
- 1-9. Select the proper procedures for disposal of regulated medical waste and hazardous wastes.

SUGGESTION

After completing the assignment, complete the exercises of this lesson. These exercises will help you to achieve the lesson objectives.

LESSON 1

SOLID WASTE DISPOSAL AT FIXED INSTALLATION

Section I. INTRODUCTION

1-1. GENERAL

a. Military units and installations generate a large variety and volume of waste. In order to safeguard the health of the command and to provide an aesthetically pleasing working environment, it is incumbent upon the military establishment to dispose of all waste products in a sanitary and efficient manner. The day of the isolated military outpost is long past. Nearly every military installation today is surrounded by a civilian community of which it is actually a component part. The pattern of consumption on the installation is largely the same as that of the civilian community, resulting in similar problems of waste disposal. As the world shrinks in size and increased productivity leads to an increase in waste and by-products, protection of the environment becomes imperative--not only from a health standpoint, but also from aesthetic considerations.

b. Proper sanitary waste disposal eliminates harborages for pests such as insects and rodents. Besides reducing the nuisance and material destruction that such pests cause, waste disposal controls the diseases transmitted by filth and pests. Such diseases include:

(1) Plague. This disease is transmitted by the rat flea.

(2) Dysentery, typhoid fever, and cholera. Intestinal diseases usually are transmitted by food and water that have been contaminated with feces or urine from an infected human or animal.

c. The content of this lesson is oriented toward solid waste disposal in fixed Army installations and to provide you with general principles of waste disposal. The principles are applicable in all situations, where appropriate; however, specific procedures peculiar to a combat or field environment are discussed in lesson 2.

1-2. RESPONSIBILITIES

To provide you with a better understanding and a bigger picture of the coordination, cooperation, interaction, and limitations of some of the agencies responsible for solid waste disposal, their responsibilities are listed below.

a. **The Surgeon General.** The responsibilities of The Surgeon General are comprehensive in nature. They include such things as:

(1) Maintaining adequate staff to support the preventive medicine mission worldwide through the provision of services and investigations in all pertinent fields.

(2) Initiating policies, preparing directives, and giving technical advice on matters pertaining to the worldwide preventive medicine mission.

(3) Making staff visits, obtaining reports, and maintaining records necessary to assure the effectiveness of the preventive medicine program.

(4) Maintaining liaison with military and other agency services, such as the Environmental Protection Agency (EPA), Public Health Service (PHS), and other regulatory governmental and concerned private agencies.

b. Major Army Commands (MACOM) and Operating Agency Commanders. MACOM and operating agency commanders are responsible for establishing procedures to ensure that health and welfare factors are considered during assessments. The MACOM are to monitor, inspect, and periodically review the operation of solid waste collection and disposal activities at installations for which they have command responsibility. Additionally, the MACOM and the Army Medical Department (AMEDD) will assist installation commanders and Directorate of Engineering and Housing (DEH) with respect to:

(1) Determining the most suitable method of solid waste disposal.

(2) Organizing the operation of collection systems to improve efficiency of performance.

(3) Reviewing, periodically, such factors as number and location of pickup stations, truck routes, type of equipment, scheduling, supervision, and personnel utilization.

(4) Selecting location and type of new sanitary landfills.

(5) Determining type of solid waste collection equipment required.

(6) Establishing waste management, resource recovery and recycling programs, and waste disposal programs in accordance with the standards outlined in regulations.

(7) Ensuring that waste management, waste minimization, resource recovery, and recycling programs are established at all installations as required by regulations, unless specific exemptions have been obtained.

NOTE: Waste minimization consists of two types of activities, reduction at the source, and recycling of waste. Source reduction refers to the reduction or elimination of waste at the point where it is generated. Recycling refers to the use or reuse

of a waste stream by-product as an effective substitute for a commercial product or as an ingredient or feedstock in a process. Fractions of waste can be recovered or reclaimed and reused. An example of this recovery and reuse include: distillation bottoms from one process can be used as a feedstock in another process. Spent battery acid accumulation by the Defense Reutilization and Marketing Officer could be used in industrial waste-water treatment facilities to precipitate phosphorus and act as a sludge conditioner.

(8) Providing Headquarters, Department of the Army (DA) with appropriate reports as required.

c. Installation and Activity Commanders. Installation and activity commanders are ultimately responsible for the following activities:

(1) Establish and conduct policy responsible for waste management minimization, resource recovery and recycling, and waste disposal programs in accordance with procedures prescribed in AR 420-47, Solid Waste Management, and AR 200-1, Environmental Protection and Enhancement. They will ensure that waste management procedures comply with the most stringent Federal, State, or local regulations at their installation. *Be aware that AR 200-1, Chapter 6 has replaced the policies, procedures, and responsibilities set forth in AR 420-47, Chapters 5 and 6. Appendices A, B, C, and the glossary.*

(2) Maintain routine liaison with the Defense Reutilization and Marketing Office (DRMO) serving the installation to maintain current information on markets for solid waste materials.

(3) Establish waste monitoring procedures to ensure minimum production of waste at the installation and to minimize the amount of waste material requiring landfill and/or incineration.

(4) Maintain liaison with Federal, State, or local authorities.

d. Directorate of Engineering and Housing (DEH). In accordance with (IAW) AR 200-1, the DEH, in conjunction with the Director of Safety, Health, and Environment (DSHE), will serve as the installation commander's expert representative for the management of waste and:

(1) Advise and monitor all waste generating activities on the Federal, State, host nation, and Army requirements for managing solid and hazardous waste to ensure compliance. The activities include tenants and subinstallations.

NOTE: The preamble to the Final Standard for Occupational Exposure to Bloodborne Pathogens, 29 Code of Federal Regulations (CFR) 1910.1030, is published in the Federal Register, Vol. 56, No. 235, Friday, 6 December 1991.

(2) Meet all requirements for managing permits, modification of permits, reporting, and record keeping, to include the treatment, storage, or disposal of hazardous waste and waste minimization (the biennial report of 40 CFR 262.41). The most cost-effective and efficient means of waste storage, treatment, and disposal will be used (existing, to be constructed, or modified) at a facility activity.

NOTE: Treatment means any method, technique, or process designed to change the physical, chemical, or biological character or composition of waste for virtually any reason, including making it safer or less voluminous (40 CFR 260.10).

NOTE: Storage means the holding of hazardous waste for a temporary period, after which it is treated, disposed of, or stored elsewhere. A generating activity becomes a de facto storer of hazardous waste if it fails to get rid of it in a timely fashion (40 CFR 260.10).

NOTE: Disposal means the discharging, injecting, dumping, spilling, leaking, or placing of hazardous or solid waste into or on land or water so that the waste or constituent thereof can be emitted into the air (burned) or discharged into surface or ground water (40 CFR 260.10).

(3) Recommend changes in policies or procedures to improve program management to the installation commander when necessary and advisable.

(4) Develop and implement a Solid and Hazardous Waste Plan that establishes the procedures and responsibilities for managing said plan or program, which includes waste minimization and resource recovery and recycling.

(5) Provide technical assistance and guidance and provide for analysis (Title 40 CFR 264.13) to waste generating activities in disposing of waste and hazardous material. Requirements include certification of activities properly identifying, segregating, and weighing materials pursuant to Federal, State, host nation, and Army requirements prior to treatment, storage, or disposal or prior to offering transportation, including to the DRMO.

(6) Review, periodically, such factors as number and location of pickup stations, truck routes, type of equipment, scheduling, supervision, and use of personnel to effectively manage solid waste.

(7) For asbestos management program, the DEH (for the Army National Guard, the Facilities Management Office (FMO)) is to establish an Installation Management Team, appoint an asbestos management control officer, and plan to manage the program. The team is to consist of the:

(a) Director of Engineering and Housing.

(b) Environmental Officer.

- (c) Preventive Medicine Officer.
- (d) Safety Officer.
- (e) Civilian Personnel Office.
- (f) Staff Judge Advocate.
- (g) Personal Affairs Officer.

NOTE: Survey results and plans are to be recorded. Past and current records are to be maintained for 30 years after the last incidence of employee exposure of asbestos. Annotate master planning documents and record drawings which indicate real property containing asbestos.

e. Installation Preventive Medicine (PVNTMED) Services. IAW AR 40-5 and AR 200-1, the installation PVNTMED personnel are to:

(1) Support the installation solid waste and hazardous waste management programs per Federal, State, and Army requirements in ARS 200-1 and 40-5. Coordinate with installation agencies such as DEH to ensure that personnel remain healthy and are protected (find the cause and eliminate or reduce its effects) from solid, hazardous, and regulated medical wastes.

(2) Monitor the installation's management of solid wastes, including the stages of segregation, storage, transportation, and disposal and/or sale so that personnel health and welfare are maintained.

(3) Assist in the management of the installation program that permits maximum opportunity for resource recovery, without jeopardizing natural resources, personnel health, and the environment.

(4) Provide technical assistance that includes investigating, identifying, and inventorying source wastes and provide consultations and special studies, as required or requested.

(5) Provide information and guidance to the installation commander and to units and activities concerning the current requirements and methods available for health related implication issues for pest control and solid waste disposal.

(6) Work to reduce the need for corrective action through controlled management of solid, hazardous, and regulated medical wastes.

(7) Evaluate installation/community complaints and provide health and welfare recommendations to the facilities engineer. Help to keep the workplace and its personnel safe from exposure to solid waste hazards by conducting announced and

unannounced inspections and surveys to ensure compliance with regulations. If exposure should occur, the mission of the preventive medicine personnel is to find the cause and to recommend to DEH the method to eliminate or reduce its effects.

(8) Represent the medical department activities (MEDDAC) and medical centers (MEDCEN) as an installation tenant and the hazardous waste generator. For example: assist the installation activities in preparing applications for landfill permits, review permits for general acceptability, and provide guidance in site selection.

f. **Installation Medical Authority (IMA).** The IMA and staff play an important role in waste disposal. It is the function of the IMA (also known as the Director of Health Services (DHS)) to know the health hazards inherent in the handling and disposal of all types of waste and to advise the commander on the health and safety aspects of waste disposal. It is also the role of the DHS to monitor all phases of waste handling techniques and procedures to ensure that no conditions exist which could constitute health hazards or nuisances to personnel and employees of the installation or to the neighboring civilian community. Where necessary and appropriate, the DHS makes recommendations to the commander concerning the sanitary aspects of waste disposal operations.

g. **The Defense Reutilization and Marketing Service (DRMS) Officer (DRMO).** The DRMO, formerly and in some places still called the Property Disposal Officer, is responsible for administering the recycling program for recyclable refuse and hazardous wastes. This responsibility includes determining the market value of waste materials, deciding which materials will be segregated for separate collection, and arranging for the issuance of recycling regulations. The DRMO is responsible for the sale, donation, reutilization, and disposal of Department of Defense (DOD) waste as prescribed in DOD 4160.21 and as outlined in AR 200-1. (Under Environmental Protection Agency (EPA) rules, a mixture listed as hazardous and solid waste must be considered a hazardous waste unless the mixture qualifies for an exemption. For the asbestos management program, DRMS will dispose of noncontract-generated asbestos as per paragraph 10-2 of AR 200-1 and will contract for pickup and hazardous waste disposal services IAW DOD 4160.21-M. It must be noted that the DRMO DOES NOT accept solid wastes such as:

(1) Toxicological, biological, radiological, and lethal chemical warfare materials, which, by United States law, must be destroyed. The Director of Logistics Agency will assist the DRMO in disposing of by-products and other materials.

(2) Ammunition, explosives, and dangerous articles (AEDA) or controlled medical items in their present forms because of military regulations.

(3) Municipal-type garbage, trash, and refuse resulting from residential, institutional, commercial, agriculture, and community activities which can be disposed of in a State or locally permitted sanitary landfill.

(4) Contractor-generated materials that are the contractor's responsibility to dispose of under the terms of the contract.

(5) Sludge and residue generated as a result of industrial plant processes or operations.

(6) Refuse and other discarded material resulting from mining, dredging, construction, and demolition operations.

(7) Unique wastes and residue of a nonrecurring nature generated by research and development experimental programs.

h. **The Director of Logistics Agency (DLA).** The DLA will handle and dispose of properly identified industrial process sludge and residue that are neither commingled nor a product of the industrial waste treatment facility.

i. **Units and Activities.** Units, activities, family quarter occupants, and other groups generating waste have important responsibilities and are held accountable for their following through with established regulations. Responsibilities include:

(1) Developing and implementing an approved Waste Management Plan and standing operating procedure (SOP) to establish procedures for the proper care of equipment, facilities, personnel, and waste. Ensuring prompt and adequate safety and precautions are being addressed, to include adequate reporting, containment, and cleanup of wastes.

(2) Ensuring that appropriate agencies, capabilities, and resources could be made available and are consistent with operational commitments to assist in adequate handling, problem solving, and disposing of wastes.

(3) Identifying a person to be responsible for daily management of solid waste and hazardous waste.

(4) Working to minimize the volume or quantity of hazardous waste prior to disposal, using economically practicable methods that emphasize source reduction, recycling, and reuse.

(5) Designing and producing material so that the end item or its components can be economically restored, reconstituted, or converted to other uses.

(6) Implementing programs to reduce or eliminate hazardous waste generated by substituting nonhazardous or less hazardous materials.

(7) Keeping the waste container pickup area clean, orderly, and accessible to pickup vehicles.

(8) Segregating refuse materials when required, as directed by the DRMO.

(9) Ensuring that hazardous and regulated medical wastes are properly identified, measured, and certified before requesting for transportation.

(10) Cleaning refuse containers (namely, the 32-gallon containers) after each pickup.

(11) Testing for effectiveness by conducting announced and unannounced inspections to ensure compliance with regulations.

(12) Identifying plans of action if exposure should occur and contingency plans to safeguard exposed personnel and those who may become exposed.

NOTE: Under new Federal Law, government employees may be held personally liable under most environmental statutes for fines and damages resulting from violation of environmental statutes. This could include commander and civil actions or penalties being taken against the individuals concerned.

j. **Liaison.**

(1) Liaison should be maintained at all levels with medical departments from other military services and appropriate representatives of Federal, State, and local health authorities and population control agencies.

(2) Appropriate AMEDD officers should maintain close liaison with Corps of Engineer (COE) staff counterparts at all levels.

1-3. TYPES OF SOLID WASTES

A military installation generates a wide variety of solid wastes, most of which are common to civilian or industrial enterprises. The following are types of solid waste.

a. **Refuse.** Refuse includes the following:

(1) Garbage.

(2) Ashes.

(3) Debris.

(4) Rubbish.

b. **Regulated Medical Waste (Infectious Waste).** Regulated medical wastes are wastes with (present) potential for causing infection such as isolation wastes, pathological wastes, and used and unused sharps.

c. **Recycled Waste (Salvaged Waste).** These are Items which may have exceeded their life expectancy or use by an activity, but which may be useful elsewhere.

d. **Hazardous Waste (Toxic Waste).** Hazardous wastes are those wastes exhibiting the properties of ignitability, corrosivity, reactivity or toxicity (such as insecticides, herbicides, or rodenticides), or listed in 40 CFR 261.

Section II. REFUSE COLLECTION AND DISPOSAL

1-4. GENERAL

The term "refuse" includes garbage, ashes, debris, rubbish, and other domestic and commercial solid waste material. Not included are garbage or other salvageable material sold under contract and delivered to a buyer at point of generation, regulated medical waste, and hazardous waste.

a. **Garbage.** Garbage consists of animal and vegetable waste and containers resulting from the handling, preparation, cooking, and consumption of foods. Edible garbage, or hog food, is the portion of waste food that has been segregated for recycling. Generally, garbage is buried in a landfill. It may also be incinerated (although incineration of refuse is highly restricted because of environmental regulations). Some living quarters and dining facilities have garbage disposal facilities. Nonedible garbage (e.g., bones) is burned or buried.

b. **Ashes.** The residue from burned wood, coal, coke, and other combustible materials. Ashes are usually buried in a landfill.

c. **Debris.** Debris includes grass cuttings, tree trimmings, stumps, street sweepings, roofing and construction wastes, and similar waste material resulting from maintenance and repair work. Some debris is recycled while other debris is disposed of in a sanitary landfill or is incinerated.

d. **Rubbish.** Rubbish consists of a variety of waste material such as metal, glass, crockery, floor sweepings, paper, wrappings, containers, carton, and similar articles not used in preparing or dispensing food. Rubbish may be further subdivided into combustible rubbish and noncombustible rubbish. Noncombustible rubbish (rubbish that cannot be burned at temperatures produced by normal rubbish incinerators [800°F to 1,800°F]) may be either disposed of in a sanitary landfill or recycled.

e. **Regulated Medical Waste.** Wastes containing biologic or pathogens (including biological fluids such as cerebrospinal fluid, blood, and sputum) and contaminated laundry should be considered pathogenic organisms and be treated as regulated medical waste material. These wastes may come from isolation wards, blood

and blood products, bandages, contaminated animal carcasses, tissue specimens, dressings, surgical waste, sharps, materials contaminated with blood, and body exudates or excreta.

NOTE: The preamble to the Final Standard for Occupational Exposure to Bloodborne Pathogens, 29 CFR 1910.1030 is published in the Federal Register, Vol.56, No. 235, Friday, 6 December 1991, Rules and Regulations. The Federal Register's rules and regulations, to include this standard, became effective on 6 March 1992.

NOTE: Bloodborne pathogens mean pathogenic microorganisms that are present in human blood and can cause disease in humans. These pathogens include, but are not limited to, hepatitis B virus (HBV) and human immunodeficiency virus (HIV).

NOTE: Contaminated laundry means laundry that has been soiled with blood or other potentially infectious materials or may contain sharps (discussed later).

NOTE: Sharps consist of needles, syringes, broken glass, and other used or unused items. Immediately following use, these instruments are to be placed in rigid, impervious containers. Needles and syringes should not be capped, clipped, or otherwise intentionally broken or destroyed prior to being placed into the containers.

NOTE: Used or unused sharps means any object that can penetrate the skin including, (but not limited to) needles, scalpels, broken glass, broken capillary tubes, and exposed ends of dental wires.

f. **Recycled Waste (Salvaged Waste).** Recycled wastes such as old automatic data processing equipment (ADPE), audiovisual equipment, typewriters, etc.

g. **Hazardous Waste.** Hazardous waste from industrial processes includes alcohols, acids, used solvents, and material containing heavy metals. Other hazardous wastes include toxic, air pollutants, paints, and other liquids containing solvents, and chemical substances or mixtures. The term does not include petroleum (including crude oil or any fraction thereof, natural gas, natural gas liquids, or synthetic gas). The Environmental Science Officer can provide the assistance. A list of these hazardous wastes is found in 40 CFR 302.4 and each is identified in 40 CFR section 261.2 or applicable foreign law, rule, or regulation.

(1) Ignitability, corrosivity, reactivity, and/or toxicity materials. For ignitability, corrosivity, reactivity, and/or toxicity materials, toxicity will probably be measured through the use of the Toxicity Characteristic Leaching Procedure (TCLP), which tests for organic and inorganic compounds and insecticides/herbicides under specified conditions believed to simulate leaching.

(2) Nonmixable used and waste oils. Category I and III type waste petroleum, oils, and lubricants (POL), such as used oils, paints, and bulk issue solvents containing levels of halogenated solvents in excess of 1,000 parts per million (ppm) or used oil containing between 100 and 1,000 ppm halogenated solvents as a result of other than normal operations, must be managed and disposed of as a hazardous waste or burned for energy recovery under 40 CFR-261 and 266.

(3) Mixable POL waste. Waste oil and Category II type waste oils (hydraulic and purging fluids, lubricating fluids, and synthetic oils) having halogenated solvents below 1,000 ppm may be blended or mixed with other Class II waste for storage prior to burning for energy recovery IAW 40 CFR 266, Subpart B.

(4) Spillage. Any spillage must be contained and every effort must be taken to prevent the spill from reaching lakes or streams. In the case of hazardous (all fuels, waste POL, and other materials) and infectious wastes, drugs, etc., you must notify proper authorities IAW SOP. Spills over 50 gallons that are contained to land areas must be reported. Sandbags or other type articles may be used to contain spillage until it can be cleaned up.

1-5. THE ESSENTIAL OF REFUSE COLLECTION

The collection and disposal of refuse is one of the major problems in sanitation for all organizations, fixed installations, and field units. Refuse handling must be approached and analyzed in terms of sound administrative engineering management and must receive the same (if not more) consideration as does other sanitary facilities. In a fixed installation, the essentials of a properly operated solid waste program are:

- a. Personnel.
- b. Segregation of refuse.
- c. Refuse collection.
 - (1) Methods.
 - (2) Frequency.
 - (3) Pickup stations.
- d. Disposal.
- e. Sanitation.
- f. Operating records.

1-6. PERSONNEL REQUIREMENTS

a. **Supervisors.** Supervisors are responsible for the efficient and economic collection and disposal of refuse. The supervisor:

- (1) Supervises collection crews.
- (2) Determines conditions and changes that affect quantities, types, or distribution of materials collected.
- (3) Effects changes in the collection system accordingly.
- (4) Assigns trucks to pickup stations when more than one type of collection vehicle is used.
- (5) Selects routes for best utilization of each type of truck.

b. **Drivers.** The truck driver is foreman of the loaders working on the truck. He is to:

- (1) Ensure that materials are kept segregated on the truck whenever required. For segregated wastes, separate trucks are needed for the separate wastes.
- (2) Report pickup stations where materials are segregated improperly.
- (3) Assist the loaders in loading heavy or unwieldy materials. On multiple container equipment, the truck driver works alone. This method saves time and manpower.

c. **Loaders.** The number of men in a truck crew, in addition to the driver, depends on the type of collection truck and the kind and quantity of refuse accumulated on the collection route. Two loaders are usually enough to work on the ground level. An additional loader is sometimes required on routes where accumulations are large, pickup stations are close together, or where ashes or other heavy materials are collected. Loaders, as well as drivers, must be:

- (1) Familiar with requirements for segregation of materials (but do not separate improperly segregated materials).
- (2) Careful to avoid spilling garbage during collection. If garbage is spilled, the loaders must clean up the area immediately.

NOTE: Trucks with special collection bodies are operated only by personnel especially trained for the work.

d. **Health Hazards.** Personnel involved in loading and disposing of refuse should be aware of and be protected against diseases they are exposed to while handling wastes. Such individuals should be trained to make use of personal hygiene measures and protective equipment in order to minimize risks. Included in these protective measures is having up-to-date immunization records.

1-7. SEGREGATION OF REFUSE

The segregation of refuse is primarily dependent upon the market value of salvageable materials. However, an inventory of hazardous waste is to be conducted and maintained by volume and/or quantity, including data tabulated by waste type and generating process. The determination is made by the DRMO and enforcement is the responsibility of unit commanders and others in charge of discarding activities.

a. The unit or activity is to ensure that commingling of hazardous wastes are enforced by implementing appropriate waste management, treatment, storage, and disposal procedures.

b. Barracks and family quarters occupants do not normally segregate refuse because of the small quantities involved. However, due to its bulk and special handling requirements, debris consisting of tree and brush cuttings, construction wastes, and other trash which will not fit into containers is normally segregated and picked up on a special schedule. Family quarters and food service facilities normally dispose of garbage by the use of garbage grinders, when so equipped, and when separate collection of edible garbage is not required.

1-8. REFUSE COLLECTION

a. **General.** The method and frequency of refuse collection depend upon a number of factors such as the size of the installation, the type of equipment available, the availability of civilian contractors, the market for salvageable materials, and the climate.

b. **Principal Types of Vehicles.** There are many types of collection vehicles available; however, collection vehicles fall into two basic types--waste-haul and container-haul. With the waste-haul vehicle, solid waste is collected from individual containers by emptying the contents into the collection vehicle. The container-haul vehicle collects and transports the filled containers.

(1) The most common type of waste-haul vehicle is the compactor truck of which there are three basic types:

(a) Front-loading compactor trucks (see figure 1-1) can collect from bulk containers. The solid waste is loaded into the top front and is compacted by a hydraulic ram which pushes the solid waste against the rear of the body.



Figure 1-1. Front-loading compactor vehicle emptying a self-loading container.

(b) Side-loading compactor trucks (see figure 1-2) can collect from bulk containers, but they are mainly used for manual loading. The solid waste is loaded from hand containers (garbage cans, plastic bags) in the front left or right side and compacted as in front loaders.

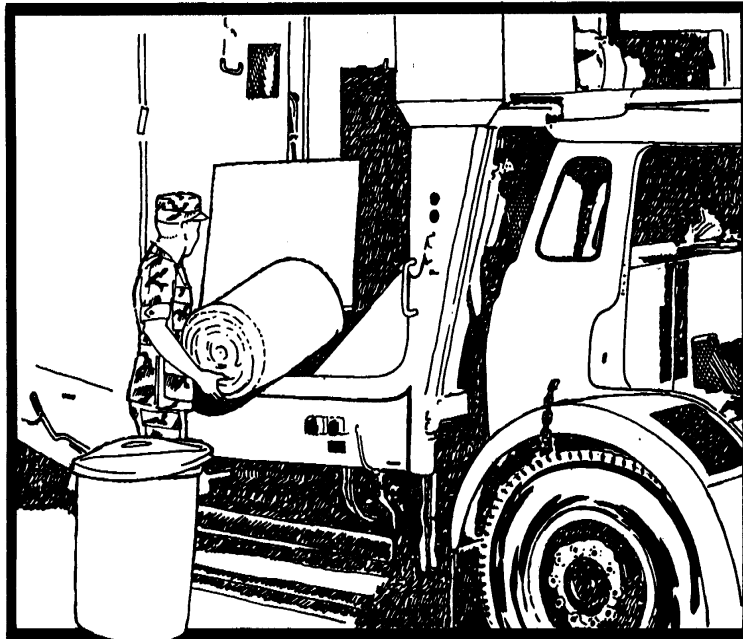

Figure 1-2. Side-loading compactor vehicle.

(c) Rear-loading compactor trucks (see figure 1-3) can collect from bulk containers but are used primarily for manual loading. The solid waste is loaded into the rear hopper and compacted by pushing the solid waste toward the front of the body.

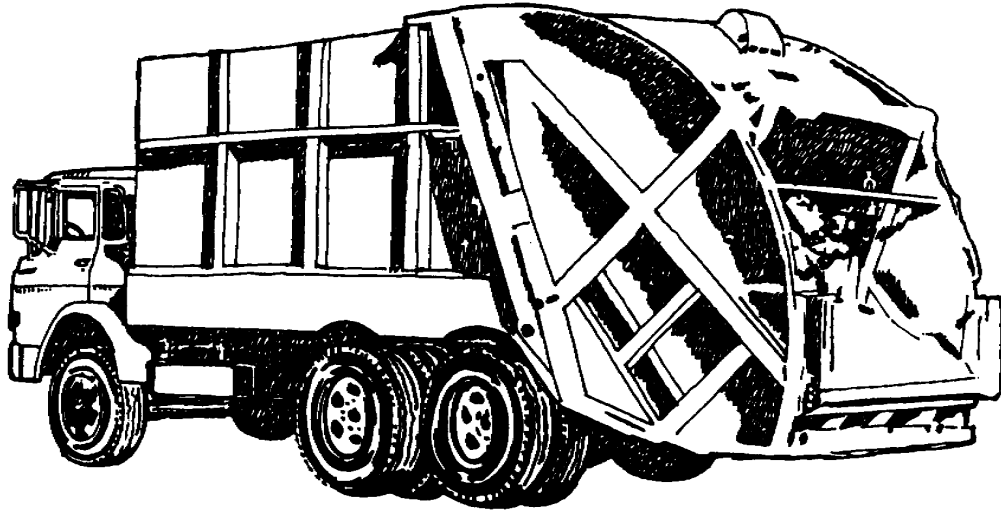

Figure 1-3. Typical rear-loading compactor vehicle.

(2) Two common types of container-haul vehicles are the hoist-and haul-vehicles (see figure 1-4) used with lugger boxes, and the tilt-frame truck (see figure 1-5) used with roll-off containers and/or large, enclosed compaction containers.

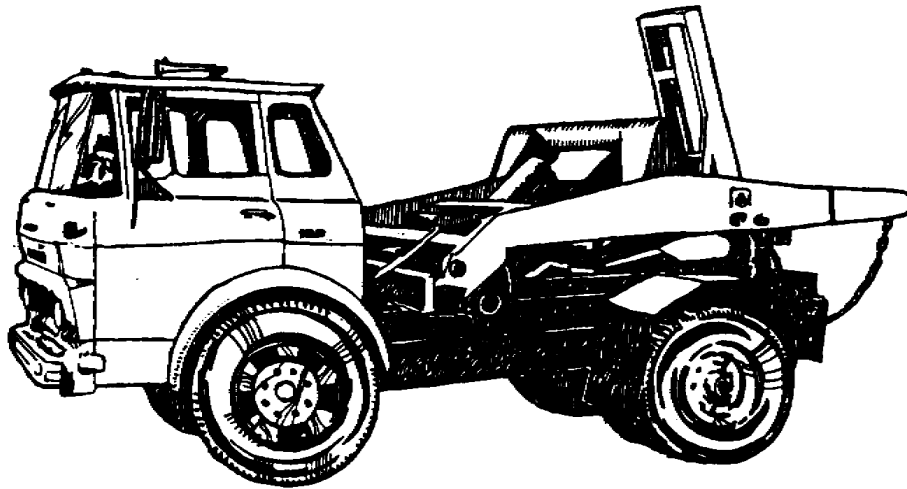

Figure 1-4. Hoist-and-haul vehicle without container

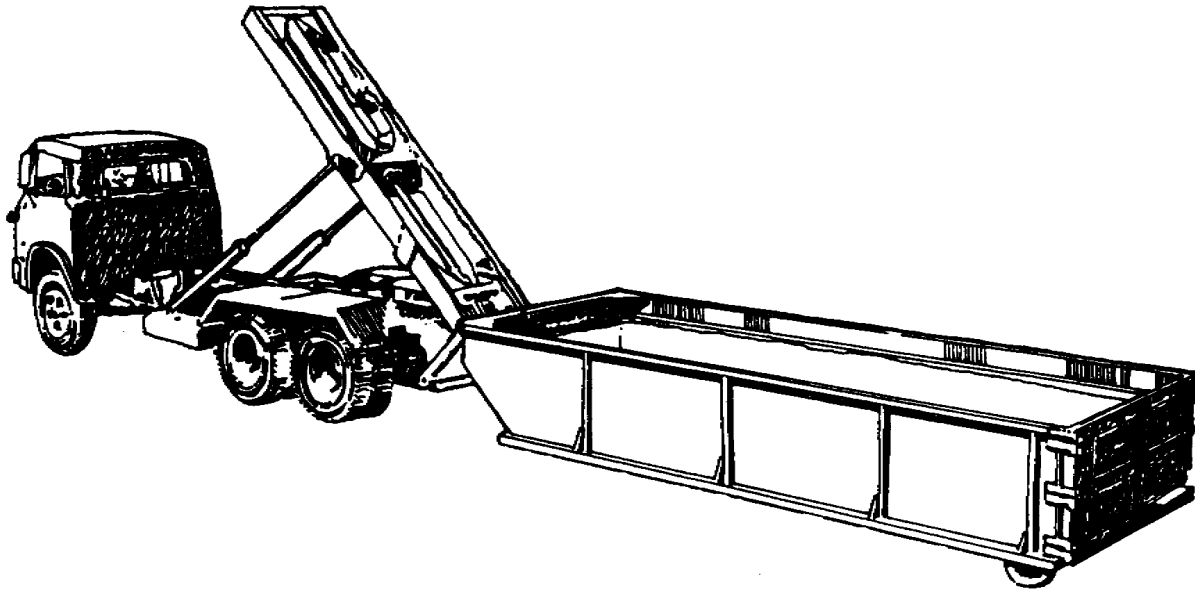

Figure 1-5. Loading a roll-off container onto a tilt-frame truck

c. **Frequency.** Army regulations prescribe that the frequency of collection should be kept to a minimum consistent with maintaining sanitary conditions and performing the service at a minimum cost. The following frequencies should not be exceeded:

(1) Garbage -- daily for dining halls and subsistence facilities; twice weekly for family quarters.

(2) Rubbish, ashes, and debris -- twice weekly.

d. **Pickup Stations.** Pickup stations are established based upon volume and types of refuse and recycling generated. They should be accessible to collection trucks and not more than 300 feet from the source of refuse material. If truck travel to the pickup station is not practicable, pickup stations should be located where minimum foot travel is required of collection crews.

(1) Dining halls, exchanges, clubs and similar facilities. A separate pickup station for each facility where food is handled, stored or dispensed.

(2) Temporary barracks. One pickup station is for every eight or ten temporary barracks when multiple container equipment is used. Two or more stations are for smaller containers or where distances between buildings are excessive.

(3) Separate family quarters. This is an individual pickup station where a 32-gallon can accommodate more than one set of quarters.

(4) Multiple family quarters. One pickup station is for each building, unless the buildings are grouped, so one pickup station can serve more than one building.

e. **Truck Routes**. The quantity of refuse accumulated daily within any one collection area may vary. It is advisable to assign one truck to adjoining routes. The truck crew can change the length of each route from day-to-day to allow for variations in quantities and still cover its area on the scheduled weekly basis. Duplication and overlapping of truck routes should be avoided. In order to collect refuse in a practical, efficient, and economic manner, truck drivers should:

(1) Begin collecting materials at points farthest from disposal facilities so there is a minimum of travel with a full load.

(2) Consider dead-end and one-way streets when planning collection routes.

(3) Cover steep grades at the beginning of the route, when the truck is partly empty.

(4) Study the road network and traffic patterns.

(5) Avoid roads and streets with heavy traffic during rush hours, whenever possible.

(6) Use side streets and secondary roads instead of primary roads to avoid interference between collections and other traffic.

f. **On-Post and Off-Post Transportation**.

(1) On-post transportation. The generator (any unit and tenant) of general waste places it in the dumpster. The Director of Logistics (DOL) is responsible for general refuse transportation.

NOTE: The transfer of wastes from one vehicle to another or from one container to another will be minimized to reduce the potential for spills.

(2) Off-post transportation. The DOL (installation commander) is responsible for ensuring that off-post transportation is in compliance with applicable regulations, the Waste Management Plan, and the Resource Conservation and Recovery Act (RCRA) permit conditions.

(3) Transportation of hazardous waste.

(a) The DOL has accountability, physical custody, and will make arrangements for proper off-post transportation of hazardous materials and waste. The DEH monitors this as in paragraphs 1-26 and 1-27 of AR 200-1.

(b) The DOL signs the hazardous waste manifest and complies with the manifest system and record keeping requirements.

(c) The transporter must have an EPA identification number and be authorized by Federal, State, local, and Army authorities to transport the hazardous waste. If outside the continental United States (OCONUS), the manifest must show the name and address of the installation command (an EPA identification number is not required) and the name, address, and EPA of the facility in the United States designated to receive the wastes (40 CFR Part 262, Subparts E and F).

(d) All Federal, State, and local requirements for packaging, labeling, marking, manifests, permits, and other requirements will be met regardless of the mode of transportation.

g. **Sanitation.** Trucks used for the collection of solid waste will be washed daily to meet sanitary requirements. Multiple containers are washed by the hoist operator as needed, depending upon the nature of the contents and the environment. For example, containers in southern Florida must be washed each time they are emptied (twice a week). Requirements will be specified in the solid waste contract that DEH issues and monitors. Containers are adequately cleaned when all food particles or other materials have been removed. Washing of garbage cans (the 32-gallon containers) is a responsibility of the units, activities, individuals, or groups of personnel placing materials in them for pickup.

h. **Operating Records.** Accurate operating records for each collection truck assigned to the refuse collection system should be kept. DA Form 3916, Daily Log of Truck Trips for Refuse and Salvage Collection, has been designed for this purpose. Truck drivers fill in the form daily, noting the size of each load (full, three-quarters, one-half, or one-quarter) or number of 32-gallon garbage cans carried on each trip. The supervisor collects the report, converts the size of load to cubic yards, and makes a monthly consolidation of this data on DA Form 3917, Refuse and Salvage Collection.

1-9. REFUSE DISPOSAL

Whenever possible, Army installations contract with civilian firms for solid waste disposal. However, installations in isolated locations or adjacent to communities too small to provide such contractors must provide their own disposal facilities.

a. **Burning.** Open burning of rubbish and debris at Army installations is prohibited by AR 200-1 and the RCRA of 1976. However, installation commanders may permit open burning of debris generated by a single undertaking (such as a construction project) provided such burning does not conflict with Federal, State, local, or Army laws. The burning must be controlled to keep air pollution to a minimum and has been specifically approved by local regulatory authorities.

b. Sanitary Landfills.

(1) The sanitary landfill is the most common and preferred refuse disposal. The principles are simple. There are two landfill methods commonly used.

(a) Area method. This method is used when the terrain is unsuitable for the excavation of trenches in which to place the wastes. Operationally, the wastes are unloaded and spread in long, narrow strips on the surface of the land in a series of layers that vary from 16 inches to 30 inches. Each layer is compacted during the course of the day until the thickness reaches a height varying from 6 feet to 10 feet. At that time, and at the end of each day's operation, a layer of cover material is placed over the completed fill.

(b) Trench method. Refuse is dumped into a trench, compacted, and covered each day with a layer of soil between 6 and 24 inches deep (see figure 1-6). The trench is dug approximately 600 feet long, 10 feet wide, and 6 feet deep. The earth from the trench is used to construct a ramp on the windward side of the trench (this is done to minimize blowing of refuse). Between loads, the trash is compacted by a bulldozer. Compacting reduces the volume of refuse to one-third or less of its original volume. The compacted trash is covered with a layer of dirt, which is compacted again. This procedure is repeated until alternate layers of compacted trash and dirt fill a section of the trench (see figure 1-7). At the end of each day, when a section of trench has been filled with compacted refuse and graded, the top, side, and end of the section are covered with earth. The cover is 2 feet at the top and 1 foot at the side. Just enough cover on the working face or end is required each day to confine the refuse and to form a seal. The compacted refuse is sealed once a week or more often by covering the working face with 1 foot of well-compacted earth. Sealing the refuse into cells provides a firebreak, controls odors, and prevents rodents from reaching the refuse. The last section of each trench should be covered with at least 2 feet of earth. Additional operational requirements may be specified in applicable Federal, State or local regulations. These requirements must be met to ensure compliance with these regulations.

(2) Sanitary fills have advantages not common to other methods of refuse disposal.

(a) Apart from truck drivers, one man with a bulldozer and a dragline bucket may be all that is needed at a small landfill.

(b) They may not require segregation of refuse.

(c) They can accommodate large fluctuations in the daily accumulation of refuse without additional personnel or equipment. Approximately 1 acre per year is allowed for each 10,000 men when the fill is to be 6 feet deep.

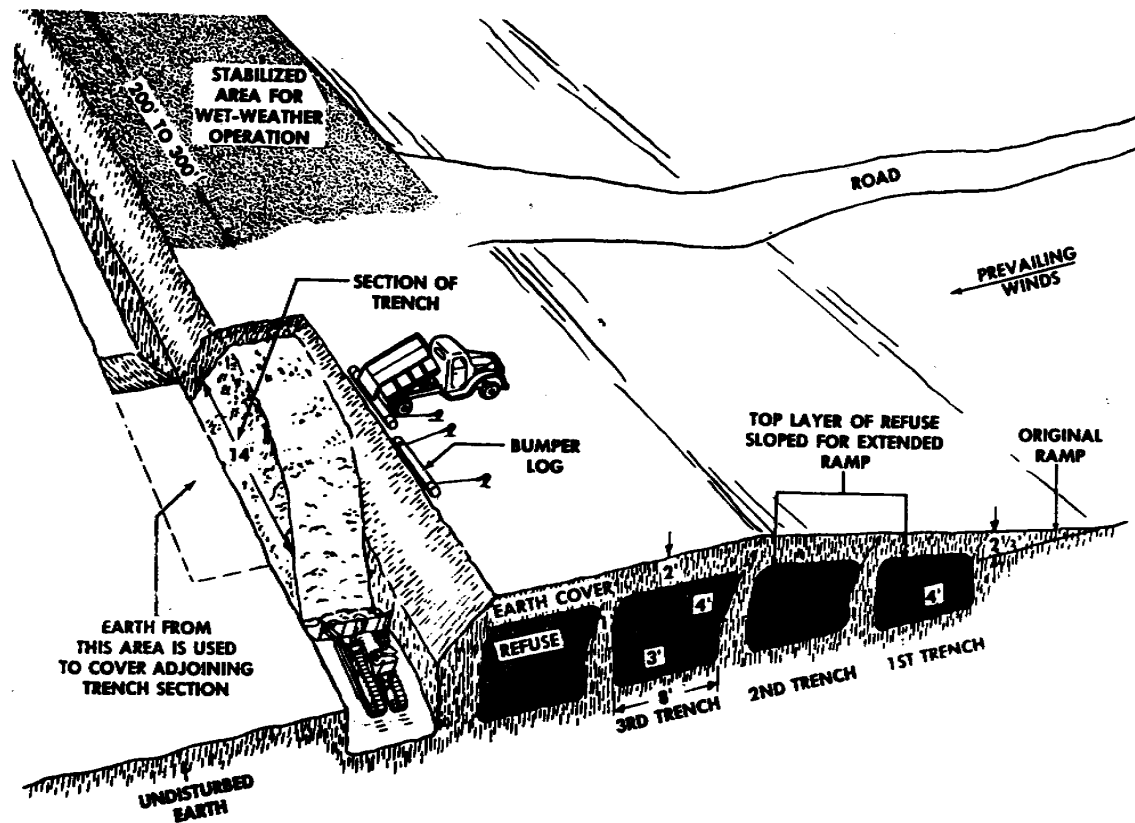

Figure 1-6. Diagram of sanitary landfill-trench method.

(d) Abandoned quarries, gravel pits, gullies, or similar areas can be used as sanitary fills, thus achieving an effective use of space. (Care must be taken to avoid permeable soils that will allow relatively easy movement of leachate from the landfill.)

(e) After the landfill has been filled with solid waste and it can no longer be used, the land can be reclaimed and used for various purposes such as a recreational area or parking lot.

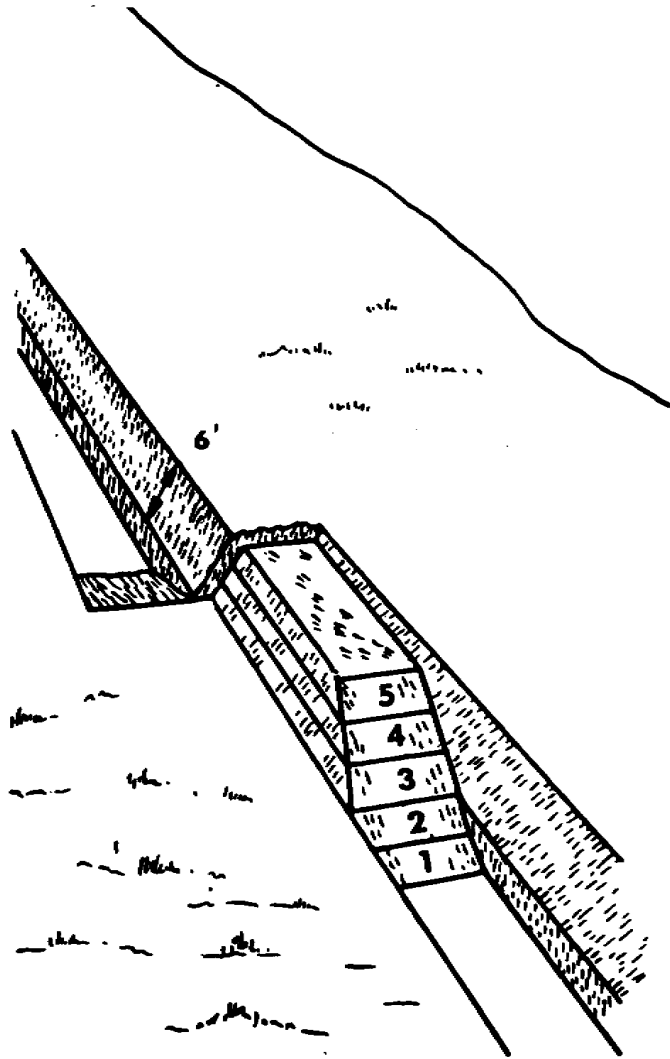

Figure 1-7. Section of trench showing layers of compacted refuse.

(3) There are many factors to consider before selecting a site for a landfill such as available land area, soil conditions, topography, and geologic and hydrogeologic conditions. Applicable Federal, State, or local regulations must be reviewed and close liaison maintained with these regulatory authorities regarding landfill site selection. A few general guidelines are presented below.

(a) Whenever possible, soft (but not sand, silt, sandy loam, or limestone) soil should be used for landfills because it is easy to excavate and cave-in when rodents dig to get the garbage. However, consideration must also be given to the water table (i.e., how deep it is) and what type of soil is present between it and the landfill. An impervious layer of soil, such as clay, is required to prevent leaching. Therefore, the soil should be easy to excavate, yet impenetrable towards the bottom so as not to contaminate the water table. All landfills must be lined to ensure protection of the water

table. This can be performed with synthetic liners or clays with low permeability (10^{-7} cm/sec percolation rates).

(b) The location of the landfill in relation to inhabited buildings is usually determined by local ordinances, economic considerations, etc. Nonetheless, 750 feet away from these buildings can be used as a rough guide.

(c) The hauling distance should be kept (roughly) to a maximum of 3 miles in order to reduce hauling costs. All-weather access roads should be provided if there is no established road already present.

(d) Provision to prevent run-on and run-off of storm water (berms [ledge at top/ bottom of slope] and drainage gullies) must be implemented to prevent erosion and protect the surrounding environment.

(e) In cold areas where the frost line extends 2 feet below the surface of the earth, landfills should not be constructed.

(4) Surveillance by medical personnel (preventive medicine personnel) is necessary to ensure that spillage of wastes are kept to a minimum and coverage done as frequently (at least daily) as necessary to prevent fly breeding and rat infestation. Frequent covering also reduces the inflow of rainfall or run-off into the fill, thus preventing the pollution of nearby ground or surface waters by leaching at the bottom.

(5) The landfill should be surrounded by 8-foot-high security fences to retain blown paper and other lightweight material and to prevent unauthorized access. When the trench method is used, the trench should be sealed twice weekly.

c. **Incineration.** Incineration is a method used at some installations for disposal of garbage and combustible rubbish. Compliance with air pollution regulations requires costly control devices on incinerators. Therefore, they are used primarily where land area is insufficient for developing sanitary fills and where incineration is the best method for disposal of regulated medical waste. Incineration will be dealt with in greater detail in Section III of this lesson.

1-10. RECYCLING (SALVAGE)

a. The recycling program is administered by the installation DRMO. Recycling includes anything which has market value and upon which contractors are willing to submit bids. Examples of recycling commodities are hog food garbage, grease, bones, wastepaper and cardboard, bottles, tin cans, waste motor oil (crankcase draining), tires, batteries, scrap lumber, and innumerable other items. The DRMO decides when materials will be segregated and placed for collection as recycling and when they will be placed as refuse. The DRMO arranges for the issuance of appropriate regulations by the installation headquarters.

b. When the quantity of edible garbage is sufficient to warrant selling it to local contractors as hog food (if local laws permit), there are several important medical implications involved. These include the following.

(1) Determining whether or not the contract provides for daily collection of the garbage.

(2) Determining whether or not the Army is protected by the terms of the contract against spillage on the installation.

(3) Determining whether garbage is cooked by the contractor before feeding it to hogs (where required by law) and preventing or inhibiting the spread of trichinosis or vesicular exanthema (a viral disease of hogs). Such a determination is not required in the interest of the health of the command, but to avoid any complicity in a possible violation of the law.

(4) Monitoring the proper cleaning of the garbage cans. Responsibility for washing garbage containers remains with the units or individuals placing the garbage for pickup.

c. Recycling paper items are folded neatly, tied, and stacked where they are protected from the weather. Glass, bottles, and tin cans are cleaned and sorted. Cans are flattened before they are placed in containers. Other items are prepared for pickup as directed locally.

d. Many installations have established recycling programs and stations. These programs should also be evaluated for potential health hazards. Preventive medicine personnel should monitor them.

Section III. INCINERATION

1-11. GENERAL

An incinerator is an engineered apparatus capable of withstanding heat and designed to efficiently reduce solid, semisolid, liquid, or gaseous waste by combustion at specified rates to residues containing little or no combustible material. Although, an incinerator occupies a small area, incineration is an expensive process because of fuel and equipment costs. It also contributes to air pollution. As a result, the incinerator is used infrequently. The sanitary landfill is the most common method of refuse disposal.

1-12. BASIC TYPES OF INCINERATORS

There are several types of incinerators designed to burn different types of waste (rubbish, garbage, mixtures of rubbish and garbage, regulated medical waste, etc.). It is

very important that the proper type of incinerator be used since fluctuations in temperature will result in damage to the incinerator or incomplete burning of waste materials. Selection of the required type of incinerator requires an in-depth knowledge. Facilities engineers are responsible for the proper operation of the incinerator.

1-13. GENERAL OPERATIONAL TECHNIQUES

In an incinerator, waste is lowered by a crane and then deposited into the charging holes by means of a conveyor belt. Fuel and air are added for combustion. Wood should never be used since high heat release could cause damage to the incinerator. Plastic, when incinerated, also raises incinerator temperatures; therefore, it is very important that only trained personnel who are aware of such factors operate incinerators.

1-14. SAFETY MEASURES

The following measures must be enforced to overcome the inherent hazards in the operation of an incinerator. Consult the installation safety office for additional specific safety requirements for incinerators.

a. **Flammable Materials.** Explosive or highly flammable materials should never be deposited into the incinerator. Gasoline, oils, asphalt, tar, live ammunition, or other hazardous materials should not be delivered or stored near the incinerator or the incinerator building. Any violations of this rule should be reported to the proper authorities.

b. **Guardrails.** Guardrails around all top-charging openings should be maintained in good condition. Personnel should be kept outside the guardrail during charging and other times when the charging openings are uncovered.

c. **Face Masks.** Plastic face masks of an approved type should be provided to operators who require them. Consult the installation preventive medicine service for proper makes.

d. **Fire Extinguishers.** Adequate fire extinguishers in good working order should be provided in the incinerator building at all times.

e. **Servicing Equipment.** Mechanical and electrical equipment, motors, and wiring should be serviced by competent mechanics. Incinerator operators should not be allowed to perform these tasks.

f. **Screens.** A 3/4-inch wire mesh screen should be placed over the top of the chimney to confine sparks and fly ash.

g. **Unauthorized Personnel.** Operation of the incinerator is an engineer responsibility. Unauthorized personnel should not be permitted inside the incinerator

building for any purpose. This also applies to collection personnel, unless they have been previously instructed in safe conduct within the incinerator enclosure.

h. **Incinerator Operating Charts and safety Notices.** Operating charts should be posted for ready reference and appropriate safety warnings should be placed in all hazardous areas. A "KEEP OUT" sign should be placed on the guardrails around the charging openings.

i. **Notices to Collection Crews.** A "Notice to Collection Crews" sign (see figure 1-8) should be placed in full view of collection truck drivers and helpers approaching the unloading platform.

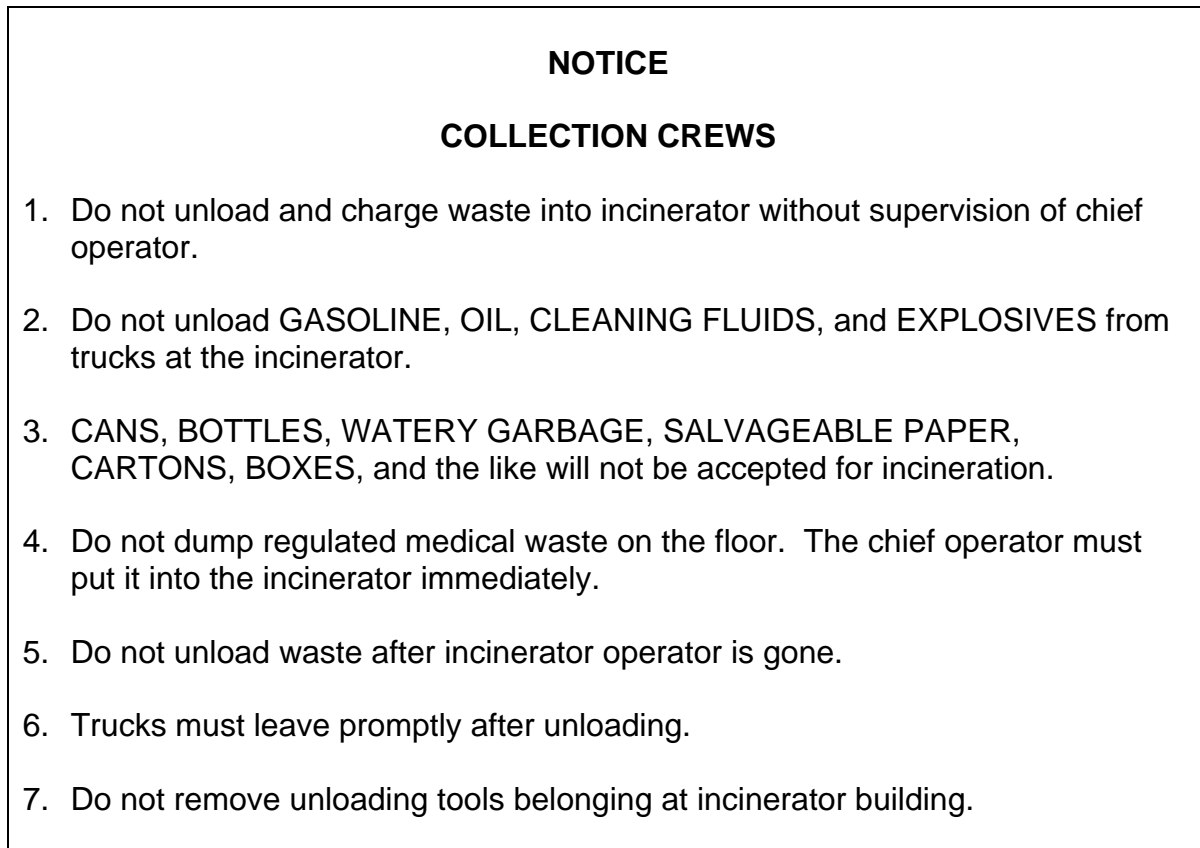

Figure 1-8. Notice, collection crews.

j. **Hazardous Waste.** All hazardous waste should be rejected. This includes flammable materials.

1-15. INCINERATOR CAPACITIES

Incineration plants are usually rated on the number of tons of combustible materials they will burn during one day. The true burning capacity of an incinerator is its ability to receive and burn combustibles in one hour within proper temperature limits.

1-16. INCINERATOR TEMPERATURES

Efficient operation of an incinerator results in burning more refuse each day with less labor and fewer repairs. High or low temperatures or rapid temperature fluctuations should be avoided to prevent injury to operators and to reduce fire hazards.

a. **Temperature Range.** In full operation, the temperatures in the combustion chamber range from 1,400°F to a maximum of 2,000°F. All combustible materials and odorous gases are consumed at an optimum temperature of 1,600°F. Prolonged higher temperatures damage refractories and castings. Fluctuations in temperatures cause the cement joints between the firebricks to break down, allowing sections of refractory to fall out, especially in the arch and hanging walls.

b. **Pyrometers.** Pyrometers are instruments for measure temperatures.

1-17. CLEANING SCHEDULE

A schedule showing the frequency for inspecting and cleaning each component of the incinerator should be developed and posted in the incinerator building. General cleaning includes:

a. Washing floors daily.

b. Removing grease with an approved cleaning compound.

c. Cleaning ashes from the base of the chimney and the flue connection, as well as grease from all sumps and floor drains. Ashes and other refuse should be removed from the incinerator daily, placed in cans or other suitable containers, and hauled to the sanitary landfill for burial at least once a week after having been tested for heavy metals content and determined to be nonhazardous waste.

1-18. RECORDS

A chronological log of inspection dates and descriptions of all repairs made should be kept. The number of cubic yards of each kind of refuse incinerated should be recorded daily.

1-19. OTHER REQUIREMENTS

a. The incinerator should be located at least 1,000 feet to 3 miles from inhabited buildings. Again, the operation of an incinerator is a sophisticated, hazardous, and expensive process requiring specially trained personnel. The environmental health specialist will probably have more contact with the sanitary landfill.

b. A copy of installation recycling regulations should be posted where it is accessible to incineration operation personnel, as well as collection crews, and

inspectors as a reminder of what materials will be delivered to the recycling yard (see para 1-10).

Section IV. DISPOSAL OF WASTES IN MEDICAL TREATMENT FACILITIES

1-20. GENERAL

a. **Overall.** Medical treatment facility personnel are to ensure that proper care, handling, and disposal of refuse; regulated medical waste; drugs, biological, and regents; and hazardous wastes are followed to prevent potential sudden and long standing problems with microorganisms, chemicals, etc. These are the items preventive medicine personnel should monitor and check during inspections and surveys.

b. Training Requirements for Handling and Disposing of Wastes.

(1) Refuse. Train personnel to follow the same reasonable practices and methods as is done for collecting refuse generated in nonmedical facilities. Personnel handling waste should receive training in the proper handling and disposal of all wastes and receive periodic refresher and sustainment training at least annually. Any new procedures should be incorporated into daily routines on an as needed basis regardless of the next training cycle.

(2) Regulated medical waste. USAHA TG 177 contains guidelines to train personnel in safe handling and disposal of regulated medical waste as does the Federal Register, Vol.56, No.235, Friday, 6 December 1991, Rules and Regulations. The Federal Register stipulates:

(a) At the time of initial assignment to tasks where occupational exposure may take place, employees are to be trained within 90 days after the effective date of the standard and at least annually thereafter.

(b) Employees having received training on bloodborne pathogens the preceding year only need training in the standard which was not included. Their medical records will be confidentially annotated.

(c) Segregation at the point of generation is one of the most important training requirements.

1-21. REFUSE

a. **Responsibilities.** Hospital, dispensary, and other medical facility commanders are responsible for the proper segregation, safe handling, collection, treatment, and transportation of all locally generated waste IAW AR 40-5.

b. **Collection of Refuse Within MTF.** Waste is to be collected at regular intervals at MTFs.

c. **Transportation of Waste Within the MTF.** Refuse waste will be transported within the MTF via easily cleaned impervious containers, unless a gravity chute or pneumatic tube system is present. If they are present, the sealed bags of waste will be placed in a large plastic bag, sealed, and transported to the system openings.

d. **Outside Pickup Stations.** Refuse is to be taken out of the facility to specified collection points for incineration or disposal at the designated and approved sanitary landfill. The waste is to be stored in leakproof containers such as compactors and dumpsters. These containers must be cleaned and sanitized as needed.

1-22. REGULATED MEDICAL WASTE

a. **Responsibilities.** Hospital, clinics, and other medical facility commanders are responsible for the proper segregation, safe handling, collection, treatment, and transportation of all locally generated waste IAW AR 40-5. Movement and disposal of regulated medical waste containers is also the responsibility of the MTF General refuse collection and disposal and operation of incinerators and/or sanitary landfills are engineering and housing responsibilities. Contingency plans must be developed and implemented to ensure safe storage, transportation, and disposal of these wastes will be carried out if the primary method is temporarily disabled or unavailable. One of the responsibilities of preventive medicine personnel is to monitor the entire process of this waste disposal.

b. **Handling of Regulated Medical Waste Inside MTF.** Regulated medical waste requires more caution and know-how by the trained handlers. The operation is usually monitored by a regulated medical waste disposal officer who makes sure that proper measures are taken. Specific handling procedures should be outlined in the infection control SOP and should include at a minimum that:

(1) Handlers must have up-to-date immunization records. When on the job, they need to wear protective clothing such as gloves, aprons, and goggles.

(2) The generating MTF will store the regulated medical waste in the area of generation until it is collected for disposal.

(3) Containers (with lids as needed) are to be lined with impervious, tear-resistant, and distinctively color-coded (see AR 385-30, Safety Color Code Markings and Signs). For example, red or orange indicates biological or regulated medical waste material that is to be autoclaved; purple specifies radiation or ionized material. Color coding of plastic bags warns employees of what they are handling and prevents the use of such cans for other purposes. Color coding is applicable for installation and field. Contaminated laundry shall be handled as little as possible with a minimum of agitation and bagged or containerized at the location where it was used and shall not be sorted

or rinsed in the location of use. These, too, need to be color-coded. According to the Federal Register, warning labels and signs shall be affixed to containers of regulated waste, refrigerators, and freezers containing blood and other potentially regulated medical waste material, and other containers used to store, transport, or ship blood or their potentially regulated medical waste materials. The warning labels and signs are to be affixed as close as feasible to the container by string, wire, adhesive, or other method that prevents their loss or unintentional removal. Signs, denoting the regulated medical waste or hazardous waste being used or tested, shall be posted at the entrance to work areas to designate that it is a Research Laboratory and Production Facility.

(4) The plastic, non-leakable, color-coded bags are to be tightly sealed or tied with rubber bands, plastic ties, or tape before being transported from the generating area.

(5) The containers are to be clearly labeled to indicate that they contain regulated medical waste consisting of sharps and are to be designed that once inserted, they cannot be removed. The containers will be safeguarded (locked in place or under supervision) to prevent access by unauthorized personnel or misuse.

(6) When full, these sharp containers will be sealed. They will be transported separately or placed in larger regulated medical waste containers and transported along the same route as other regulated medical waste and incinerated, autoclaved, or destroyed by another approved method. The sharps must be rendered unusable. If transported off-post, their manifest will follow the same procedure as for regulated medical waste.

(7) Regulated medical waste is to be collected at regular intervals by the trained staff or by trained contractor personnel.

(8) If it is necessary to store pathological waste, the sealed bag or container is to be refrigerated until it is transferred for treatment.

c. Transportation of Regulated Medical Waste Within the MTF.

(1) Regulated medical waste is to be transported with the original sealed plastic bags in carts, if available, for easier hauling.

(2) Carts used to transport regulated medical waste should be of a kind that can be easily cleaned.

(3) Routes used for transporting the waste will be carefully selected to minimize congestion and exposure.

d. **Outside Pickup Stations for Regulated Medical Waste.** Manifesting and/or tracking of hazardous waste is to be followed by applicable regulations.

NOTE: Under no circumstances will medical wastes be transported by privately owned vehicles.

e. **Transportation of Regulated Medical Waste.**

(1) The containers, carts, or dumpsters used to store, transport, or dispose of this waste must be cleaned before they are returned to the MTF.

(2) Manifest must be logged.

f. **Disposal of Regulated Medical Waste.**

(1) Incineration. Waste contaminated with disease organisms and/or offensive materials (bandages, sacrificed animal carcasses, tissue specimens, dressings, surgical waste, food service waste from regulated medical waste disease wards, materials contaminated with blood, body exudates or excreta, regulated medical waste incident to hospital and operation) will be disposed by incineration as the preferred method. Incineration of regulated medical waste should only be conducted with incinerators specifically designed for these wastes. Human excreta and fluid wastes will be disposed through normal sewage facilities, if acceptable.

NOTE: Ensure that the incinerator permit is current as per Federal, State, and local air pollution regulations.

NOTE: The manifest procedure is to be continued, quantified, signed by the receiving official, and the receipts returned and made part of the MTF generator's record of waste production and disposal.

(2) Autoclave. When feasible, regulated medical waste may be sterilized or autoclaved by pressurized steam prior to disposal as general waste, providing microbiological testing is employed to ensure proper sterilization or rendered noninfectious. Pathological waste may be incinerated or steam sterilized and its ash can be disposed of at the sanitary landfill.

NOTE: If pathological waste is steam sterilized, it will be destroyed (ground) and then flushed into the sanitary sewer or incinerated.

NOTE: The use of boiler fires for this purpose is prohibited.

(3) Ash, nonregulated medical waste. The ash or nonregulated medical waste, having been treated by steam sterilization, can be disposed of at the sanitary landfill.

1-23. BIOLOGICALS, DRUGS, AND REAGENTS WASTE

a. Drugs, biologicals, and reagents (chemicals) incident to hospital operations will be disposed of in accordance with AR 40-61. Guidance for destruction is contained in DOD Disposal Manual (DOD 4160-21-MD).

b. Drugs, biologicals, and reagents determined unfit for issue or use must be destroyed under the guidance of the IMA. Destruction will be accomplished in a manner compatible with physical, chemical, and hazardous properties and to minimize potential health hazards and destruction cost. Destruction will be IAW local air and water pollution control standards.

1-24. HAZARDOUS WASTES

a. **Chemical and Biological Warfare Agents and Munitions.** Disposal of chemical and biological warfare agents, hazardous products, and deteriorated ammunitions and explosives will be IAW Army regulations. Every effort will be made to dispose of these wastes in such a manner so as to minimize the environmental pollution and comply with environmental regulations. A Chemical Hygiene Plan is to be developed and implemented stating specific measures that the employer will take to ensure laboratory employee protection. The Chemical Hygiene Plan should include each of the following elements and shall indicate specific measures that the generating activity or employer will take to ensure laboratory employees are protected.

(1) Develop an SOP to establish safe working procedures and safe removal of contaminated waste plus incorporate decontamination procedures.

(2) Establish criteria the employer will use to determine and implement control measures for handling hazardous and regulated medical wastes and to reduce employee exposure to hazardous chemicals, etc., including engineering controls and the use of personal protective equipment and hygiene practices, especially with chemicals known to be extremely hazardous.

(3) Establish designated work, storage, and disposal areas.

(4) Provide for medical examinations and consultations.

(5) Provide initial and continuous information and training to employees on how to detect the presence or release of hazardous chemicals and how to label, use, and dispose of the containers.

b. **Chemicals and Chemical Products.** Chemicals and chemical products will be disposed of or destroyed in a manner that is compatible with their physical, chemical, and hazardous properties, which minimizes environmental effects and disposal costs. Release of these substances may be in the form of continuous or intermittent discharge incident to normal installation activity or may involve specialized bulk disposal or

destruction. All disposals will be IAW Federal, State, and local air and water pollution control standards. Guidance on proper disposal may be requested as specified in AR 40-5.

c. **Hazardous Materials.** With the exception of oils and other liquid petroleum products, it is difficult to identify materials which should be classified as hazardous. A waste is considered hazardous if it is specifically listed as such in 40 CFR Part 261 or has the following characteristics: ignitability, corrosivity, reactivity, and/or toxicity. Certain chemicals, such as asbestos, cadmium, lead, mercury, beryllium, cyanide, toxaphene, polyvinylchloride, polychlorinated biphenyls (PCBs), fluorine compounds, selenium, arsenic, and certain pesticides are recognized as hazardous and special storage and handling are necessary even for small quantities. Other materials, however, are more difficult to categorize since excessive amounts of almost anything can be harmful when released. Numerous environmental regulations include provisions for controlling the storage, treatment, disposal, and discharge of hazardous wastes as described in 40 CFR Part 260-271. A detailed discussion of provisions of these regulations is beyond the scope of this course. At the installation level, the DEH and DRMO can be contacted to provide specific guidance on the storage, treatment, disposal, and discharge limitations of hazardous wastes.

d. **Transportation of Hazardous Waste.** For transporting hazardous waste, only certain selected routes and vehicles are to be used. This ensures maximum safety and exposure reduction in the event of an accident.

(1) Transportation routes will be inspected and approved by the DEH to ensure compliance with Federal, State, local, and Army requirements.

(2) A hazardous or regulated medical waste manifest is not required to transport the waste within the confines of the installation, but is off post. The generating activity should, however, document the date, time, and location of delivery; the quantities; and the receiving official's name.

NOTE: No deliveries of hazardous waste will be made without first notifying and obtaining approval from the receiving agency.

Continue with Exercises

EXERCISES, LESSON 1

INSTRUCTIONS: Answer the following exercises by marking the lettered response that best answers the exercise, by completing the incomplete statement, or by writing the answer in the space provided at the end of the exercise.

After you have completed all these exercises, turn to "Solutions to Exercises" at the end of the lesson and check your answers. For each exercise answered incorrectly, reread the material referenced with the solution.

1. Which insect and rodent diseases do proper sanitary waste disposal help to eliminate?
 - a. Common cold and plague.
 - b. Dysentery and pimples.
 - c. Typhoid fever and cholera.
 - d. Hay fever and dysentery.

2. Which of the following is the responsibility of The Surgeon General as it relates to waste disposal?
 - a. Maintain adequate staff.
 - b. Make staff visits and obtain reports.
 - c. Maintain liaison with other military services.
 - d. Initiate policies for worldwide preventive medicine mission.
 - e. All of the above.

3. A major responsibility of the MACOM in solid waste disposal, is to:
 - a. Recommend changes in policies or procedures to improve program management to the installation commander when necessary and advisable.
 - b. Initiate policies, prepare directives, and give technical advice on matters pertaining to the worldwide preventive medicine mission.
 - c. Make staff visits, obtain reports, and maintain records necessary to assure the effectiveness of the preventive medicine program.
 - d. Determine the most suitable method of solid waste disposal.

4. Which statement is correct concerning waste minimization?
 - a. Waste minimization consists of two types of activities, reduction at the source and recycling of waste.
 - b. Recycling refers to distillation from one process which can be used as a feedstock in another process.
 - c. All waste can be recovered or reclaimed and reused.
 - d. Spent battery acid accumulation could be used in industrial waste-water treatment facilities to precipitate alcohols.

5. If an installation commander needs to set up a new sanitary landfill, where could he go for assistance?
 - a. MACOM.
 - b. Unit.
 - c. DIA.
 - d. DRMO.

6. Which of the following is a function of the facilities engineer?
 - a. Ensure that operating personnel receive adequate training.
 - b. Maintain past and present records for 30 years after the last incidence of employee exposure to asbestos
 - c. Purchase any pesticides they choose.
 - d. Supervise and direct pest management.

7. Who is ultimately responsible for all phases of waste disposal at a fixed installation, excluding health care facility waste?
 - a. DEH.
 - b. DHS.
 - c. Installation commander.
 - d. DRMO.

8. Preventive Medicine Services personnel:
 - a. Are to know the health hazards inherent in the handling and disposal of all types of waste and to advise the commander on the healthy aspects of waste disposal.
 - b. Are responsible for the sale, donation, reutilization, and disposal of DOD waste.
 - c. Are responsible for finding the cause of a harmful exposure and recommending to DEH the method to eliminate or reduce its effects.
 - d. Dispose of property identified as industrial process sludge and residue that are neither commingled nor a product of the industrial waste treatment facility.

9. Which organization or agency is to identify a person responsible for daily management of solid and hazardous waste?
- a. DLA.
 - b. DRMO.
 - c. DOL.
 - d. Each unit and activity.
10. Units, activities, or individuals are responsible for washing which of the following?
- a. Multiple containers.
 - b. 32-gallon containers.
 - c. Infectious waste containers.
 - d. 48-gallon containers.
11. The four types of solid wastes are:
- _____.
- _____.
- _____.
- _____.
12. Rubbish consists of:
- a. Animal and vegetable waste resulting from the handling, preparation, cooking, and consumption of food.
 - b. Metal, glass, floor sweepings, and cartons.
 - c. Tree trimmings, stumps, street sweepings, and grass cuttings.
 - d. Residue from burned wood, coal, coke, and other combustible materials.

13. Ashes consist of:

- a. Animal and vegetable waste resulting from the handling, preparation, cooking, and consumption of food.
- b. Coal, vegetables, grease, and debris.
- c. Tree trimmings, glass, street sweepings, and grass cuttings.
- d. Residue from burned wood, coal, coke, and other combustible materials.

14. What are five of the essentials of a properly operated solid waste program?

15. The three refuse collection steps or operations are:

16. What is one of the personnel requirements for the refuse collection supervisor?

- a. Select routes for best utilization of each type of truck.
- b. Ensure that materials are kept segregated on the truck whenever required.
- c. Assist the loaders in loading heavy or unwieldy materials.
- d. Be familiar with requirements for segregation of materials so that they are not improperly separated.

17. _____ report pickup stations where materials are segregated improperly.

- a. Supervisors.
- b. Drivers.
- c. Loaders.
- d. Foremen.
- e. b and c.

18. The _____ assigns trucks to pickup stations when more than one type of collection vehicle is used.

- a. Supervisor.
- b. Driver.
- c. Loader.
- d. Foreman.

19. The segregation of refuse primarily dependent upon:

- a. Who is picking it up.
- b. The market value of salvageable materials.
- c. The inventory.
- d. The DRMO.

20. How should an inventory of hazardous waste be conducted and maintained?
- By volume and/or quantity, including data tabulated by waste type and generating process.
 - As seen fit by the DRMO.
 - By the number of trucks available.
 - By estimations from the truck driver and foreman.
21. Which group of people DO NOT normally segregate refuse but do separate bulk and debris consisting of tree and brush cuttings, construction wastes, and other trash?
- Drivers.
 - Loaders.
 - Barracks and family quarters occupants.
 - DRMO personnel and foreman.
22. Which are the most common type of container-haul vehicles used for lugger boxes and the tilt-frame truck?
- Front-loading compactor and side-loading compactor trucks.
 - Rear-loading trucks and hoist vehicles.
 - Haul-vehicles and side-loading trucks.
 - Hoist-and haul-vehicles.

23. How often should garbage be picked up from dining halls and subsistence facilities?
- a. Daily.
 - b. Biweekly.
 - c. Weekly.
 - d. Twice a day.
24. How often should garbage be picked up from family quarters?
- a. Daily.
 - b. Weekly
 - c. Twice a week.
 - d. Twice a day.
25. Pickup stations should be accessible to collection trucks and not more than _____ feet from the source of refuse materials
- a. 300.
 - b. 350.
 - c. 400.
 - d. 450.

26. What must truck drivers consider when selecting truck routes to collect refuse in a practical, efficient, and economical manner?
- a. Dead-end and one-way streets when planning collection routes.
 - b. Steep grades should be covered at the beginning of the route, when the truck is partly empty.
 - c. Avoid roads and streets with heavy traffic during rush hours whenever possible.
 - d. a and b only.
 - e. a, b, and c.
27. As PVNTMED personnel, whom would you check with to ensure that hazardous waste transportation routes were inspected and approved?
- a. DEH, generating activity, and receiving agency.
 - b. NCOIC and transportation office.
 - c. DRMO, housing authority, and generating office.
 - d. MACOM and unit activity.
28. Where would hazardous or regulated medical waste need to be transported for a manifest to be required and who would have to be notified?
- a. On post; generator.
 - b. Off post; receiver.
 - c. On and off post; receiver.
 - d. Any place; generator and receiver.

29. Who issues the contract and how often must refuse trucks be cleaned (each State has different rules)?
- DOL; once a week.
 - DEH; each time refuse is emptied.
 - Host unit; twice a week.
 - Generator; each time refuse is emptied.
30. When may open burning of rubbish or debris take place on post?
- Anytime under a new rule in AR 200-1.
 - When the installation commander says it's OK, if it doesn't conflict with existing laws, and if it is controlled.
 - Twice a week.
31. With sanitary landfills, for what type of land is the area method used and how high could the layering go?
- Sandy like in Florida; 5 feet.
 - Firm like in Maryland; 20 feet.
 - Rocky like in San Antonio; 10 feet.
 - Good, rich, and arid like in California; 15 feet high.
32. Using the trench method, why is it important to construct a ramp on the windward side (see figure 1-6)?
- To minimize the blowing of refuse.
 - To get a push up the ramp.
 - To use up the dirt from the trench.
 - To control air pollution.

33. What advantage do sanitary landfills have that are not common to other methods of refuse disposal?
- a. One man with a bulldozer and a dragline bucket may be all that is needed at a small landfill.
 - b. They may not require segregation of refuse and, if filled with solid waste, the land can be reclaimed for recreational area use and parking lots.
 - c. They can accommodate large fluctuations in the daily accumulation of refuse without additional personnel or equipment
 - d. a and b only.
 - e. a, b, and c.
34. To be used as a sanitary landfill, the land must be:
- a. Easy to excavate, impenetrable towards the bottom (lined or layered with clay, impervious soil, or synthetic liner), and of an acceptable water table level.
 - b. Easy to excavate, penetrable towards the bottom, and of an acceptable water table level.
 - c. Hard to excavate, impenetrable towards the bottom (lined or layered with clay, impervious soil, or synthetic liner), and of an acceptable water table level.
 - d. Easy for rodents to dig through and of a low water level.
35. To reduce costs, what is the maximum hauling distance to a sanitary landfill?
- a. 1 mile.
 - b. 3 miles.
 - c. 5 miles.
 - d. 7 miles.

36. What changes are to be made to the land to prevent run-on and run-off of storm water (prevent erosion) and to protect the surrounding environment?
- Line up bulldozers.
 - Use garbage as a blockage.
 - Dig berms and drainage gullies.
 - Keep adding soil.
37. A duty of PVNTED personnel is to monitor the sanitary landfill to ensure that:
- Spillage of wastes is kept to a minimum.
 - People are working.
 - Coverage is done as frequently (at least daily) as necessary to prevent fly breeding and rat infestation.
 - a and c.
38. Why should eight feet high fences surround sanitary landfills?
- Retain blown paper and similar materials.
 - Prevent unauthorized access.
 - Hide the landfill.
 - All of the above.
 - Only a and b above.

39. In a sanitary landfill, the refuse is dumped into a trench, compacted, and covered/sealed _____ with a layer of soil between 6 and 24 inches deep.
- a. Twice a week.
 - b. Four times a week.
 - c. Five times a week.
 - d. Daily.
40. How far should a sanitary landfill be from inhabited buildings?
- a. 750 feet.
 - b. 800 feet.
 - c. 850 feet.
 - d. 900 feet.
41. What will an impervious layer of soil at the bottom of the sanitary landfill prevent?
- a. Rodents from harboring.
 - b. Mildew.
 - c. Bleaching.
 - d. Leaching.
42. Which method is used at some installations with little land area to dispose of garbage and combustible rubbish?
- a. Sanitary landfill.
 - b. Recycle.
 - c. Incinerate.
 - d. Burial in two-foot trench.

43. Because new and tougher air pollution regulations have been enacted, what changes have occurred with the incineration method?
- a. Compliance to regulations requires more costly control devices.
 - b. It is used primarily where land area is insufficient for sanitary landfills and where incineration is the best method.
 - c. Its use has increased to burn noncombustible waste as well.
 - d. a and b only.
 - e. All of the above.
44. Who is responsible for administering the recycling program?
- a. DEH.
 - b. DRMO.
 - c. DLA.
 - d. PVNTMED.
45. Although recycling programs at installations are being established, PVNTMED personnel should monitor them for possible:
- a. Eye sore appearances.
 - b. Health hazards.
 - c. Funding overages.
 - d. Damage to the equipment.

46. Why is it important to use the proper type incinerator for refuse burning?
- Fluctuations in temperature will result in damage to the incinerator.
 - Fluctuations in temperature will result in complete burning of waste materials.
 - Burning requires a large area.
 - Paper folded neatly, tied, and stacked will burn evenly.
47. With which incinerator safety measures should management be concerned?
- Servicing equipment.
 - Guardrails.
 - Chimney screen.
 - Flammable materials.
 - All of the above.
48. Why is it important to keep the incinerator temperature range between 1,400° F and a maximum of 2,000° F, with 1,600° F as the optimum?
- Prolonged higher temperatures damage refractories and castings.
 - Prolonged lower temperatures damage refractories and castings.
 - Fluctuations in temperatures cause the cement joints between the firebricks to break down, allowing sections of refractory to fall out, especially in the arch and hanging walls.
 - a and c.

49. Which statement is correct concerning a Notice to Collection Crews? (see figure 1-8.)
- Dump regulated waste on the floor.
 - Unload waste after incinerator operator is gone.
 - Trucks can leave after unloading.
 - Do not remove unloading tools belonging at incinerator building.
50. What should be posted and accessible to incineration operation collection personnel, crews, and inspectors?
- Assignment orders.
 - Installation recycling regulations.
 - Remnants of what was burned.
 - A yard stick.
51. Why should PVNTMED personnel monitor medical treatment facility disposal of wastes?
- To prevent pilferage.
 - To ensure that proper care, handling, and disposal of refuse; infectious wastes; drugs, biological, and reagents; and hazardous wastes
 - To prevent potential sudden and long standing problems with microorganisms, chemicals, etc.
 - b and c.

52. Which of the following statements is/are true concerning the training requirements for the handling and disposal of other waste?
- a. USAEHA TG 177 and the Federal Register, Vol.56, No. 235, Friday, 6 December 1991 contains guidelines to train personnel in safe handling and disposal of regulated medical wastes.
 - b. When assigned, employees are to be trained within 90 days after the effective date of the standard and at least annually thereafter.
 - c. If trained on bloodborne pathogens the preceding year, only training in the standard which was not included will be taught.
 - d. All of the above.
53. What type of plans must be developed in case something goes wrong with primary procedures for regulated medical waste?
- a. New plans.
 - b. Special plans.
 - c. Contingency plans.
 - d. Different plans.
54. Which of the following statements is/are correct concerning the handling of regulated medical waste inside the MTF?
- a. Specific handling procedures should be outlined in the regulated medical waste (infection) control SOP.
 - b. Handlers must have up-to-date immunization records.
 - c. When on the job, handlers need to wear protective clothing such as gloves, aprons, and goggles.
 - d. Containers are to be lined with impervious, tear-resistant, and distinctively color-coded plastic bags and contaminated laundry shall be handled as little as possible.
 - e. All of the above.

55. As an inspector, what do you check on the manifest to ensure that regulated medical waste was incinerated according to regulations?
- a. The amount is quantified, signed by the receiving official, and receipts are returned to the MTF generator's record.
 - b. Both the generator's and receiver's records.
 - c. a and b.
 - d. The autoclave for wear.
56. Which statement is NOT correct concerning destruction of biological, drugs, and reagents?
- a. When used in hospitals, they will be disposed of IAW AR 40-61 and guidance for destruction is contained in DOD Disposal Manual (DOD 4160-21-MD).
 - b. Those determined unfit for issue or use must be destroyed under the guidance of IMA.
 - c. Destruction will be accomplished with minimal potential health hazards present, minimal cost, and IAW local air and water pollution control standards.
 - d. They will be placed in a large, deep sanitary landfill and buried forever.
57. What is to be developed and implemented by the employer to ensure that laboratory employees are protected from hazardous wastes?
- a. Biological Sanitary Plan.
 - b. Chemical Hygiene Plan.
 - c. Incinerator Plan.
 - d. Common Sense Plan.

58. A waste is considered hazardous if it:
- a. Is specifically listed as such in 40 CFR Part 261.
 - b. Has the following characteristics: ignitability, corrosivity, reactivity, and/or toxicity.
 - c. Is a certain chemical such as carbon monoxide.
 - d. a and b above.
59. If you have checked the regulations and are still not sure how to store a hazardous item, what agency should you contact at installation level to seek assistance?
- a. DEH or DRMO.
 - b. DLA.
 - c. IMA.
 - d. Safety officer.

Check Your Answers on Next Page

SOLUTIONS TO EXERCISE, LESSON 1

1. c (para 1-1b(2))
2. e (para 1-2a)
3. d (para 1-2b(1))
4. a (para 1-2b(7) NOTE)
5. a (para 1-2b(4))
6. b (para 1-2d(7))
7. c (para 1-2c)
8. c (para 1-2e(1))
9. d (para 1-2i(3))
10. b (para 1-2i(10))
11. Refuse
Infectious waste
Recycled (salvaged) waste
Hazardous waste (para 1-3)
12. b (para 1-4d)
13. d (para 1-4b)
14. Any five of the following:
Personnel
Segregation of refuse
Refuse collection
Disposal
Sanitation
Operating records (para 1-5)
15. Methods
Frequency
Pickup stations (para 1-5c)
16. a (para 1-6a (5))
17. b (para 1-6b(2))

18. a (para 1-6a(4))
19. b (para 1-7)
20. a (para 1-7)
21. c (para 1-7b)
22. d (para 1-8b(2))
23. a (para 1-8c(1))
24. c (para 1-8c(1))
25. a (para 1-8d)
26. e (para 1-8e)
27. a (paras 1-2d(2)(6), 1-8f(1), 1-24d)
28. b (para 1-24d)
29. b (para 1-8g)
30. b (para 1-9a)
31. c (para 1-9b(1)(a),(3)(a))
32. a (para 1-9b(1)(b), figure 1-6)
33. e (para 1-9b(2))
34. a (para 1-9b(3)(a))
35. b (para 1-9b(3)(c))
36. c (para 1-9b(3)(d))
37. d (para 1-9b(4))
38. e (para 1-9b(5))
39. a (para 1-9b(5))
40. a (para 1-9b(3)(b))

41. d (para 1-9b(4))
42. c (para 1-9c)
43. d (paras 1-9c, 1-11)
44. b (para 1-10)
45. b (para 1-10d)
46. a (para 1-12)
47. e (para 1-14)
48. d (para 1-16a)
49. d (figure 1-8)
50. b (para 1-19b)
51. d (para 1-20a)
52. d (para 1-20b)
53. c (para 1-22a)
54. e (para 1-22b(1)(2)(3))
55. c (para 1-22f(1) NOTE)
56. d (para 1-23a, b)
57. b (para 1-24a)
58. d (para 1-24c)
59. a (para 1-24c)

End of Lesson 1

LESSON ASSIGNMENT

LESSON 2

Solid Waste Disposal in the Field.

TEXT ASSIGNMENT

Read and study paragraphs 2-1 through 2-11.

LESSON OBJECTIVES

After completing this lesson, you should be able to:

1. Select the statement that correctly describes the differences between waste disposal under field conditions from that of installations waste disposal.
2. Define garbage and the procedures for disposal.
3. Identify the types of incinerators and the procedures to operate them.
4. Select the statement that correctly describes the definition of rubbish and procedures for disposal in the field.
5. Select the statement that correctly describes procedures for field disposal of liquid/solid kitchen wastes.
6. Select the statement that correctly describes the procedures for disposal of regulated medical waste, hazardous, biological, drugs, and reagent wastes in the field.
7. Select the preventive medicine (PVNTMED) procedures used when soldiers are exposed to environmental health hazards.

SUGGESTION

After completing the assignment, complete the exercises at the end of this lesson. These exercises will help you to achieve the lesson objectives.

LESSON 2

SOLID WASTE DISPOSAL IN THE FIELD

Section I. INTRODUCTION

2-1. GENERAL

In the Army, manpower is the most valuable asset. Everything possible must be done to conserve this asset. Success in battle? the ultimate objective of any military force? demands that troops be maintained in a constant state of combat readiness. Field hygiene and sanitation contribute to this effort by employing all of the measures designed to protect and improve the health of the fighting force.

2-2. MEDICAL IMPORTANCE OF FIELD WASTE DISPOSAL

A substantial part of the waste produced each day in the field consists of solid waste such as garbage and rubbish. If this solid waste is not removed promptly and thoroughly, a camp or bivouac area would soon become a smelly, filthy dump. Flies, rats, and other vermin would be attracted and would add to the individual's discomfort as well as endanger each soldier's health. Even with the relatively good level of sanitation maintained in the U.S. Army camps of World War II, records show a total of nearly 1 million hospital admissions for filth-borne diseases during that period. Here are two examples.

a. The 134th Artillery and the 404th Engineer Battalions were part of a Pacific Ocean task force preparing to attack Guadalcanal. Fifty-five percent of the engineers and 65 percent of the artillerymen contracted a disease called "filariasis" which was transmitted by mosquitoes. Both units had to be replaced (medically evacuated) without firing a shot against the enemy. With the use of insect repellent, insecticides, and elimination of standing water, this loss of soldiers could have been prevented.

b. During the initial stages of Desert Storm, after the U.S. Armed Forces had landed and were setting up in Saudi Arabia, the troops did not follow standard procedures. In their rush to prepare to fight in the operation, field sanitation measures were not enforced and bacteria multiplied. The numbers of operational latrines and hand washing facilities (or antiseptic hand cleaners) were not sufficient. Some soldiers failed to wash their hands after visiting the latrines and others were bitten by the infected flies and mosquitoes. Some deep pit latrines and pail latrines were not cleaned and spilled over, enticing flies and mosquitoes who transmitted diseases. Therefore, many soldiers became sick with a bowel disease known as dysentery and others contracted malaria. They were rendered incapacitated for a while. Television coverage showed the unsafe conditions and aftermath. They also showed preventive medicine

personnel bringing Field Sanitation Teams (FST) to train the unit soldiers on proper sanitation procedures. The problems were noted and corrected quickly.

2-3. RESPONSIBILITIES

a. The types of waste generated in the field are very similar to those found on an installation (garbage, rubbish, hazardous, and regulated medical waste). However, the problem of waste disposal under field conditions differs from that of a garrison situation in two important ways:

(1) The installation engineer exercises overall responsibility for waste disposal facilities and services on the installation, whereas in the field, the commander of each unit is responsible for waste disposal activities within his unit in the field situation.

(2) Another difference is that while installation solid waste disposal facilities are of a permanent nature, those used in the field are usually temporary and improvised. In earlier days, Romans disposed of solid wastes by "open dumping." No longer can solid waste be disposed of in such a manner. Units in the field cannot take waste disposal for granted. A lack of attention to waste disposal activities in the field can quickly result in a breakdown of proper sanitation procedures with the resultant increase in disease and infections among unit personnel.

b. Federal and State legislatures have implemented laws that are aimed at protecting our environment. The U.S. Army regulations are often complex and difficult to find. Most soldiers are unfamiliar with their requirements but are learning quickly. Therefore, The Commander's Guide to Environmental Law was developed to guide the commander in understanding environmental obligations (installation and field) and helpfully highlighting requirements of laws and regulations. Because it is a guide, the commander is to contact appropriate agencies for specific and technical guidance.

Section II. SOLID WASTE DISPOSAL IN THE FIELD

2-4. FIELD DISPOSAL OF HUMAN WASTE

The disposal of human waste, essentially urine and feces, constitutes a major part of the waste and disposal problem in the field. Obviously, when units train in the field, human waste poses a threat to our environment and to the soldiers. Sanitation and proper hygiene are as important as food and shelter. If not properly contained, human waste can directly contaminate our water supply and can indirectly contaminate our water supply by leaching into underground water sources. It also poses a threat of disease directly and by providing a breeding ground for insects and other pests. However, the construction of field latrines can also damage our environment and, in some cases, approval is required before they are constructed (new environmental laws

dictate such). A more detailed coverage is in Subcourse MD0161, Wastewater Treatment. This subject is also covered to some extent in other subcourses dealing with field sanitation.

2-5. FIELD DISPOSAL OF GARBAGE

Garbage is the solid or semisolid waste. It includes the animal and vegetable waste and containers resulting from the preparing, cooking, and serving of food. Garbage is disposed of by burial or incineration.

a. Burial.

(1) On the march, on bivouac, or in camps of less than 1 week's duration, garbage is normally buried in pits or trenches. For this purpose, a pit of 4 feet square and 4 feet deep is suitable for 1 day for a unit of 100 men. The burial area is covered after each dump, then sprayed with insecticide, and covered at the end of the day. When filled to within 1 foot of the surface, the pit should be sprayed with insecticide, filled in with earth, and mounded over with an additional foot of compacted earth. Compacting the earth is very important; it helps deny flies and rodents access to the garbage. The pit or trench should then be marked with a sign placed on the mound, indicating the type pit and the date closed (if the tactical situation permits such advertising).

(2) The continuous trench is more adaptable to stays of 2 days or more. The trench is first dug about 2 feet wide, 4 feet deep, and long enough to accommodate the garbage for the first day. As in the cover after each dump of waste pit method, the trench is filled to not more than 1 foot from the top. The trench is extended, as required, and the excavated dirt is used to cover and mound the garbage already deposited. This procedure is repeated daily or as often as garbage is dumped.

(3) Pits or trenches should not be over 30 yards from the food service area. Garbage should not, however, be buried closer than 100 feet to any source of water used for drinking or cooking.

b. Incineration.

(1) Garbage may be burned and reduced to ashes, which may be used for fill; but the burial method is considered to be better and should be used whenever possible. If burial is not practicable, an incinerator may be constructed for use in the field if the tactical situation permits.

(2) Since incinerators will not handle wet garbage, it is necessary to separate the liquid from the solid portion. This is done by straining the garbage with a coarse strainer such as an old bucket, salvaged can, or 55-gallon drum (see figure 2-1) in which holes have been punched in the bottom. The container or barrel incinerator serves more efficiently as a filter if it is filled with material such as rocks, crushed cans,

sticks, or grass and covered with a screen. The solids remaining in the strainer are incinerated and the liquids are poured through a grease trap into a soakage pit or trench. Field incinerators should be located at least 50 yards downwind from the camp to prevent an odor nuisance.

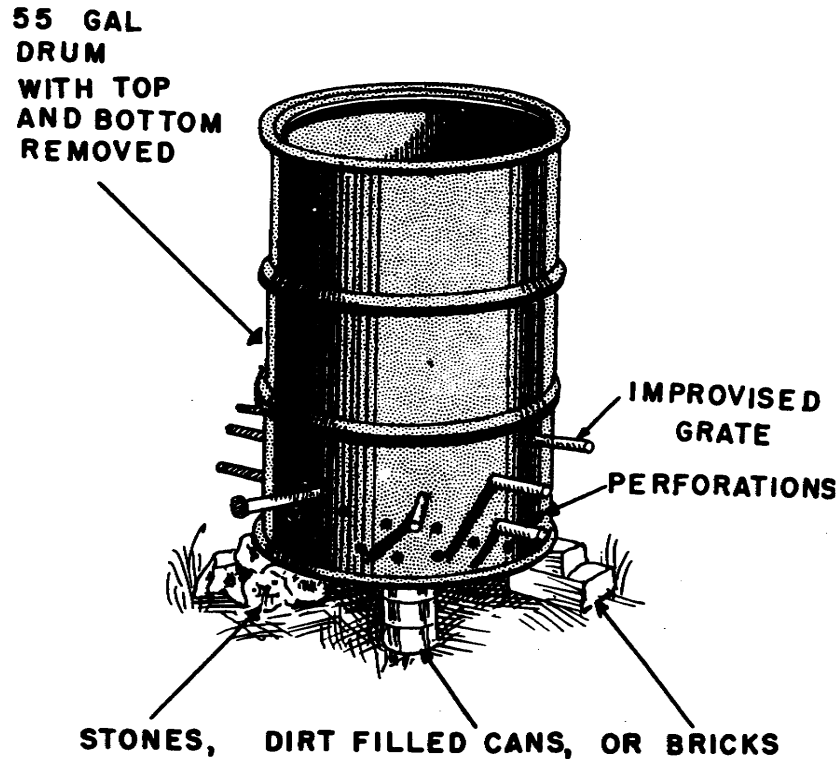

Figure 2-1. Barrel incinerator.

(3) The inclined plane incinerator (see figure 2-2) can be used to dispose of garbage. The construction and operation of an inclined plane incinerator is described below.

(a) The sheet metal plane is inserted through telescoped 55-gallon drums, from which the ends have been removed.

(b) The metal plane should extend approximately 2 feet beyond the upper end of the telescoped drums to serve as a loading or stroking platform.

(c) The telescoped drums are positioned in an inclined surface.

(d) A grate is placed at the lower end of the telescoped drums and a wood or fuel fire is started under the grate.

(e) After the incinerator becomes hot, garbage is placed on the stroking platform. As the garbage becomes dry, it is pushed through the telescoped drums in small amounts to burn. Final burning takes place on the grate.

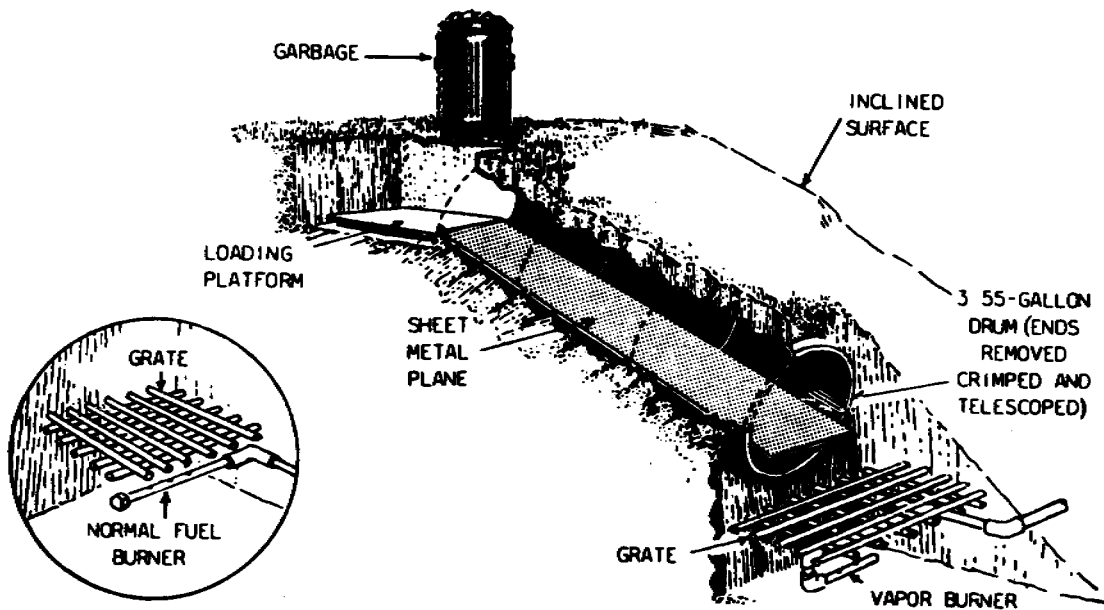

Figure 2-2. Inclined plane incinerator.

2-6. FIELD DISPOSAL OF RUBBISH

Rubbish consists of wastes which originate in the field tent quartering areas, latrines, medical areas, administrative and office areas, supply and depots, etc. Rubbish includes items such as wastepaper, plastics, wood, metal, glass, ashes, splints, and cloth. Rubbish may be classified as combustible or noncombustible. Since a unit in the field generates a lot of waste, it can damage our environment. To protect the environment, a simple rule is, "If you brought it to the field, then bring it back." All areas need to be policed on a daily basis and before the unit leaves. All refuse and garbage must be returned to garrison or the DEH approved dump. None will be buried in the field if the unit is to be there for a day.

a. **Wire.** All communication, concertina, and barbed wire, etc. must be collected and returned to the installation when training is completed. If refuse or wire was left from previous exercises, it is to be picked up, too.

b. **Burying of Rubbish.** In temporary camp or on bivouac, all rubbish usually is buried in pits or in trenches with the garbage. If this is done, care should be taken to flatten the tin cans and break down the boxes before they are added to the rubbish.

c. **Incineration of Rubbish.** In carps where the length of stay is over 1 week, the combustible rubbish is either buried or hauled to a suitable disposal site. The barrel incinerator is made from a 55-gallon drum by cutting out both ends, punching many

holes near the bottom, and inserting grates inside the barrel several inches above the holes. The barrel is supported several inches above the ground on stones, bricks, or dirt-filled cans, thus allowing space to build a fire under the barrel. The rubbish is put into the barrel on the top grate. [Figure 2-1](#) illustrates a barrel incinerator.

d. **Disadvantage of Burning Garbage.** Major disadvantages of burning garbage or rubbish in a combat situation are giving your location away to the enemy by the smoke and odor and giving clues in forecasting future locations. If any burning is done, caution should be used also in the spreading of fire.

NOTE: All fires are to be monitored, from start to completion. Sparks from fires, flames too high for the area, and smoldering flames can cause disastrous effects to the environment and personnel.

2-7. FIELD DISPOSAL OF LIQUID/SOLID KITCHEN WASTES

In the field, liquid kitchen waste is disposed of in the soil usually by means of either soakage pits or soakage trenches. However, food particles, soap, and grease (solvents) are contained in this water. For the soil to absorb these liquids, the grease and soap, as well as any solid particles, must first be filtered out or removed before the liquid can be disposed. For this reason, a grease trap is made a part of each soakage pit or trench to be used for the disposal of wash and liquid kitchen waste. In places where heavy clay soil prevents the use of soakage pits or trenches, evaporation beds may be used.

a. Soakage Pits and Trenches.

(1) Soakage pits.

(a) In a temporary camp, a soakage pit 4 feet square and 4 feet deep will normally be adequate to dispose of liquid kitchen waste for 200 persons. If the troops are to remain in the camp for 2 weeks, two pits should be constructed for disposal of liquid kitchen waste; each pit should be used on alternate days, thus lessening the possibility of clogging.

NOTE: Do not dump kitchen grease waste directly into the soakage pit because clogging will rapidly occur. Instead, filter the wastes through a grease trap, with the water going into a soakage pit and the filtered grease being buried.

(b) These soakage pits are constructed in the same way as a urinal soakage pit (see figure 2-3), except that the urinal pipes are omitted. A grease trap is provided for each kitchen pit. Should a soakage pit become clogged, it is closed and a new one is constructed. A soakage pit is closed by covering it with 1 foot of compacted earth and marked. It is marked by placing a sign on top of the mound. The sign must indicate the type of pit, the date closed, and the unit designation.

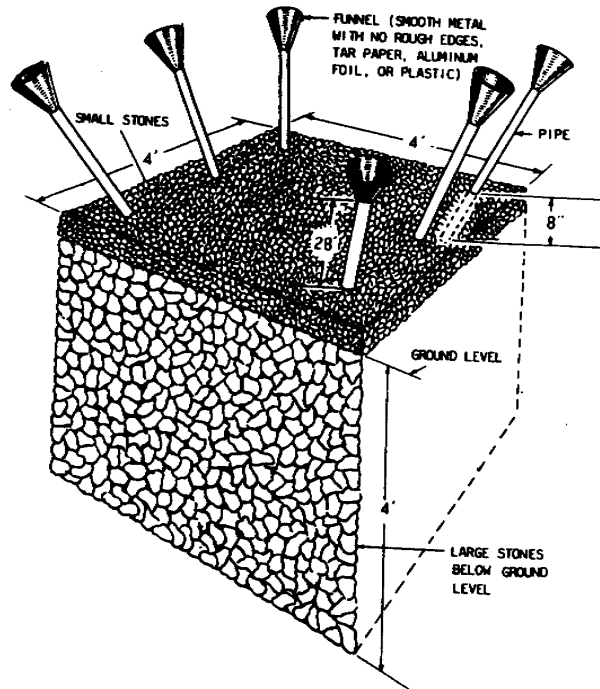

Figure 2-3. Urinal soakage pit with pipes.

(c) In addition to fire prevention, maintaining a clean field kitchen presents additional environmental risks. Pits or reservoirs serving as a drain or receptacle for liquids (sump holes) may be dug to dispose of kitchen water. However, draining particles, soapy water, or chlorinated water into lakes or rivers is prohibited. AR 40-5 and FM 21-10 specify a thorough police of the area must be accomplished.

(2) Soakage trenches. If the groundwater level or a rock formation exists close to the surface, soakage trenches should be used instead of pits. A soakage trench consists of a pit 2 feet square and 1 foot deep with a trench extending outward from each of its sides for a distance of 6 or more feet (see figure 2-4). The trenches are 1 foot wide and vary in depth from 1 foot at the central pit to 18 inches at the outer ends. The pit and trenches are filled with the same types of material as used in a soakage pit. Two such units should be built to dispose of liquid kitchen waste for every 200 persons; each unit being used on alternate days. The waste should first pass through a filter grease trap. One unit should be built for each washing device provided. A soakage trench is closed by covering it with 1 foot of compacted earth and marked in the same manner as a soakage pit.

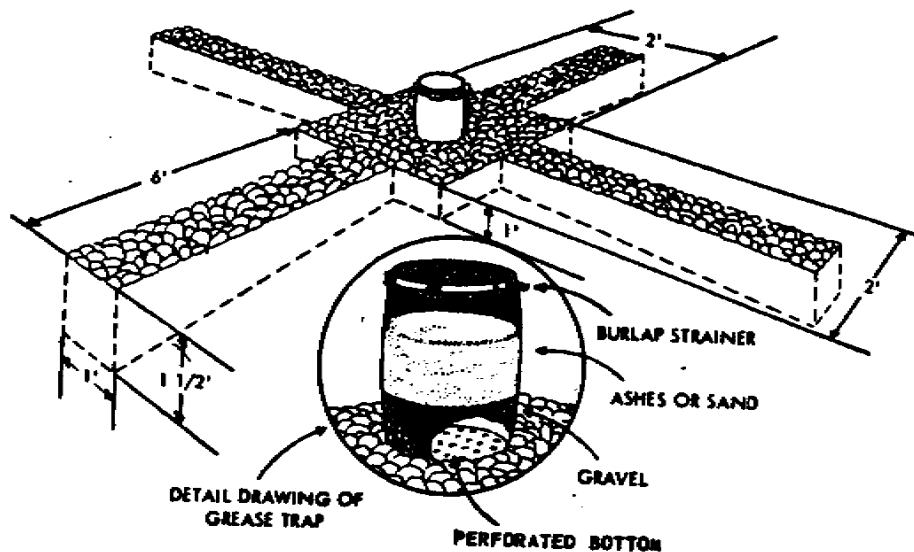

Figure 2-4. Soakage trench with barrel filter grease trap.

b. Grease Traps.

(1) Baffle grease traps. A baffle grease trap may be made from a drum (see figure 2-5 A) or from a watertight box (see figure 2-5 B). The drum or box is divided vertically into an entrance chamber and an exit chamber by attaching a wooden baffle. The baffle should be placed so that the entrance chamber will be approximately twice the size of the exit chamber. The baffle should hang to a point within 1 inch of the bottom. A strainer, which may be made from a small, perforated box filled with straw, hay, or burlap, is placed in the entrance chamber. An outlet pipe is inserted into the exit chamber about 3 to 6 inches below the top as an outlet to the soakage pit. This baffle grease trap is usually placed on the ground at the side of the soakage pit with the outlet pipe extending 1 foot beneath the surface at the center of the pit. If a grease trap is not watertight, it must be placed partially under the ground.

(a) Before the grease trap is used, the chambers are filled with cool water. The waste liquid is poured through the strainer, which retains any solids. As the warm liquid strikes the cool water, the grease rises to the surface of the entrance chamber and the liquid runs under the baffle, filling the exit chamber. When the liquid reaches the outlet pipe near the top of the exit chamber, it runs through this pipe into the soakage pit. Unless the grease trap is of sufficient capacity, the warm greasy liquid poured into the trap will heat the cool water in the trap, thus allowing the grease to remain uncongealed and to pass through the trap. The efficiency of this grease trap can be increased by constructing it with multiple baffles. Also, a series of traps may be used.

(b) The baffle trap must be properly maintained to prevent clogging of the soakage pit. The grease retained in the trap should be skimmed daily from the surface of the water or as often as required. It is either buried or burned. The entire trap should be emptied and thoroughly scrubbed with hot, soapy water as often as necessary.

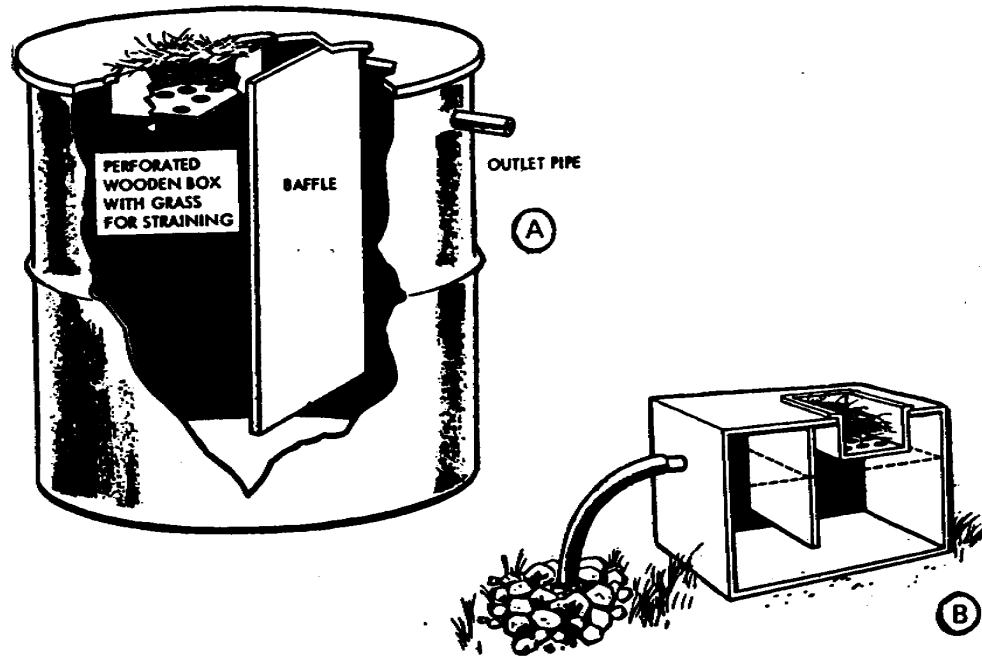

Figure 2-5. Baffle grease traps: (A) barrel type (B) box type.

(2) Barrel filter crease trap. The barrel filter grease trap (see figure 2-6) may be made from a 30-to 55-gallon barrel or drum which has had its top removed and a number of large holes bored into the bottom. Eight inches of gravel or small stones are placed in the bottom and covered with 12 to 18 inches of wood ashes or sand. A piece of burlap is fastened to the top of the barrel to serve as a coarse strainer. The trap may be placed on a platform with a trough leading to a soakage pit or placed directly over a soakage pit. If it is placed directly over the pit, the bottom may be removed instead of having holes bored in it. Every two days, the grease trap should be emptied, washed, and refilled with fresh ashes or sand. The old ashes or sand should be buried. The burlap filter should be either washed or replaced every day.

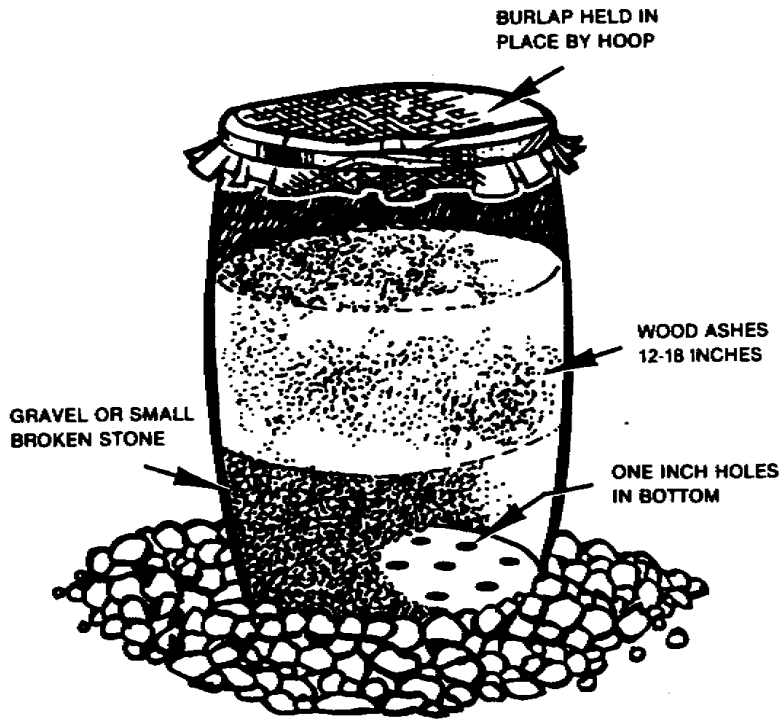

Figure 2-6. Barrel filter grease trap.

2-8. FIELD DISPOSAL OF REGULATED MEDICAL (INFECTIOUS) WASTE

a. Refer to Lesson 1 of this subcourse for the definition of regulated medical waste and those responsible to ensure that regulated medical waste is handled properly at an installation. However, in a field environment, there is an increase in the possibilities of personnel being exposed to regulated medical waste since personnel are in a less standardized and sterile environment. Additional sanitary measures need to be incorporated by unit users and medical personnel. Because of the greater risk for contracting an infection or disease from regulated medical waste, preventive medicine personnel need to be more conscious of the environment, the conditions, and safety procedures in handling and disposing of regulated medical waste. Potentially regulated medical waste materials/fluids include:

- (1) Sharps.
- (2) Pathological wastes (tissues, organs, and body parts).
- (3) Human blood and blood parts (items saturated with blood).
- (4) Isolation ward wastes.
- (5) Culture and stocks.

(6) Animal wastes.

b. The preferred method of disposal of regulated medical waste material in the field is proper and efficient incineration and then burial in a separate pit.

c. Another method available is autoclaving (putting slides, tubes, etc., under super-heated steam) and then burying the waste.

NOTE: DO NOT use autoclave that is used for sterilizing instruments, cloth, etc.

d. The inclined plane incinerator (see figure 2-2) may be used to dispose of regulated medical waste.

NOTE: In no situation should regulated medical waste be burned in an open fire or barrel incinerator (see figure 2-1).

2-9. FIELD WASTE DISPOSAL OF BIOLOGICALS, DRUGS, AND REAGENTS WASTE

a. Drugs, biologicals, and reagents (chemicals) used at field aid stations, make-shift laboratories, and hospitals are to be disposed of in accordance with AR 40-61 and 40 CFR 261. Guidance for destruction is contained in DOD Disposal Manual (DOD 4160-21-MD).

b. Those material products determined unfit for issue, expiration date being reached, slides no longer needed, etc., must be destroyed according to Federal, State, local laws, and Army regulations. Any special guidance for destruction is to come from the IMA.

2-10. FIELD DISPOSAL OF HAZARD WASTE

a. **Chemical and Biological Warfare Agent and Munitions.** Disposal of chemical and biological warfare agents, toxic products, and deteriorated ammunitions and explosives will be IAW 40 CFR 261, Appendix H and Army regulations. The goal is to minimize environmental pollution and protect personnel.

b. **Chemicals and Chemical Products.** Chemicals and chemical products will be disposed of or destroyed in a manner which is compatible with their physical, chemical, and toxic properties and minimizes environmental effects and disposal costs. Release of these substances may be in the form of continuous or intermittent discharge incident to normal installation activity or may involve specialized bulk disposal or destruction. All disposals will be IAW Federal, State, and local air and water pollution control standards. Guidance on proper disposal may be requested as specified in AR 40-5.

c. Hazardous Materials.

(1) Ignitability, corrosivity, reactivity, and/or toxicity materials. For ignitability, corrosivity, reactivity, and/or toxicity materials, toxicity will probably be measured through the use of the Toxicity Characteristic Leaching Procedure (TCLP), which tests for organic and inorganic compounds and insecticides/herbicides under specified conditions believed to simulate leaching.

(2) Nonmixable used and waste oils. Category I and III type waste (POL such as used oils, paints, and bulk issue solvents) containing levels of halogenated solvents in excess of 1,000 parts per million (PPM) or used oil containing between 100 and 1,000 ppm halogenated solvents as a result of other than normal operations must be managed and disposed of as a hazardous waste or burned for energy recovery under 40 CFR 261 and 266.

(3) Mixable POL waste. Waste oil and Category II type waste oils (hydraulic and purging fluids, lubricating fluids, and synthetic oils) having halogenated solvents below 1,000 ppm may be blended or mixed with other Class II waste for storage prior to burning for energy recovery IAW 40 CFR 266, Subpart B.

(4) Spillage. Any spillage must be contained and every effort must be taken to prevent the spill from reaching lakes or streams. In the case of spills of hazardous waste (all fuels, POL, and other materials), regulated medical waste, drugs, etc., the proper authorities must be notified IAW SOP. Spills over 50 gallons that are contained to land areas must be reported. Sandbags or other type articles may be used to contain spillage until it can be cleaned up.

(5) Maintenance of vehicles. Field maintenance of vehicles is to be limited. When required, care must be exercised to ensure that no POL, grease, rags or toweling, and the like be dumped or spilled on the ground by soldiers. All waste POL must be placed in drums and returned to garrison for recycling. Vehicles will not be washed in or near any lake or stream.

2-11. REQUESTING PREVENTIVE MEDICINE ACTION

If soldiers are exposed to environmental health hazards such as caused by some type of solid waste disposal, preventive medicine personnel need to follow certain procedures when requested to investigate. They need to determine the cause of the outbreak and, amongst other things, make recommendations to the commander. Generally speaking, these are the procedures they would follow.

a. **Determine Patient Symptoms.** When a request to investigate a suspected health hazard is received, the preventive medicine personnel check with the medical authorities or the commander to obtain soldier symptoms (for example: cold sweats, lung damage, skin or eye irritations, diarrhea, fever) so that they have an idea of what to

look for at the site. If insufficient data is available to determine the presence or absence of contamination or disruption, then samplings are needed.

b. Survey the Site. One of the first things the preventive medicine personnel would do is to survey the site with safety and DEH personnel for possible clues, take samples of the contaminated items, disease, or materials involved or generated. Good indications that something is wrong is if one or all of the following environmental changes are noted:

(1) Trees, forests, soil, and woodlands are defoliating, wilted, diseased, or turning brown.

(2) Fish and wildlife populations and habitats are diseased, dying, or damaged in some way.

(3) Surface water or groundwater supplies are murky, foul smelling, filled with debris, etc., as is wetlands and/or flood plains.

(4) Illegal dumping or hazardous materials, substances, or wastes by non-Army parties come on to Army bivouac areas.

(5) Unexplained human illness or the injury or death of wildlife, domestic animals, aquatic life, or vegetation when occurring to such an extent as to suggest more than a random event.

(6) Spills of oil, regulated medical waste, or hazardous substances.

c. Perform Risk Assessment. Analyze the samples for the exact cause. Determine the extent of the problem and risk, including possible ramifications or impact to humans and wildlife.

d. Follow Evaluation Procedures. Evaluate the adequacy of the existing data to determine the potential for the presence or absence of contamination or impact. Summarize the potential for exposing existing and future soldiers or human populations to the adverse environment.

e. Make Recommendations to the Commander. Summarize all identified contamination or disruptions and state their impact on soldiers, including technical justification, and annotate recommendations to the commander. Recommend to mitigate or control adverse impacts and to protect personnel from hazardous exposures. Often, the cause was that personnel did not follow SOP. Sometimes, only minor modifications or alterations are needed to correct the problem so it does not occur again. Sometimes a recommendation involves training or retraining personnel to follow correct procedures.

Continue with Exercises

EXERCISES, LESSON 2

INSTRUCTIONS: Answer the following exercises by marking the lettered response that best answers the exercise, by completing the incomplete statement, or by writing the answer in the space provided at the end of the exercise.

After you have completed all these exercises, turn to "Solutions to Exercises" at the end of the lesson and check your answers. For each exercise answered incorrectly, reread the material referenced with the solution.

1. Which are two measures designed to contribute to the effort to protect and improve the health of our military fighting force?
 - a. Supply economy and leaching.
 - b. Sanitation and field hygiene.
 - c. "Open dumping" and field hygiene.
 - d. Rodent control and bivouaging.

2. Which solid wastes are substantial parts of daily field waste?
 - a. Liquid waste and garbage.
 - b. Rubbish and ammunition.
 - c. Debris and ashes.
 - d. Garbage and rubbish.

3. The total weight of all various wastes produced in the field could be as high as _____ per day.
 - a. 100 pounds.
 - b. 50 pounds.
 - c. 25 pounds.
 - d. 10 pounds.

4. Even with a relatively good level of sanitation in recent wars, which problem has caused an abundance of hospital admissions?
 - a. Wounds.
 - b. Allergies.
 - c. Filth-borne diseases.
 - d. Boots that were too tight.

5. If insect repellents and insecticides had been used and standing water eliminated, what major problem would mosquitoes not have caused to our fighting units?
 - a. Hay fever that wiped out the majority of two units.
 - b. Unit discomfort with insect bites.
 - c. Filariasis that rendered two combat units to stand down.
 - d. Soldiers running for insect repellent.

6. What is the title of the soldiers in the unit trained in sanitation procedures?
 - a. Combat casualty care personnel.
 - b. Field Sanitation Team.
 - c. Utilities Utilization and Food Preparation Team.
 - d. Medics.

7. Who supervises waste disposal in the field?
 - a. The installation engineer exercises overall responsibility for waste disposal facilities and services on the installation.
 - b. The commander of each unit in the field is responsible for waste disposal activities within his unit.
 - c. The unit commander in the field supervises the preventive medicine personnel, environmental officers, and the DRMO.
 - d. a and b above.

8. How does the problem of field waste disposal differ from that on a garrison?
 - a. While installation solid waste disposal facilities are of a permanent nature, those used in the field are usually temporary and improvised.
 - b. Open dumping is permitted on post but not in the field.
 - c. While the field solid waste disposal facilities are of a permanent nature, those used on the installation are usually temporary and improvised.
 - d. Environmental laws only pertain to field conditions and not to those of a garrison.

9. The Commander' s Guide to Environmental Law:
 - a. Relieves the commander of his responsibilities.
 - b. Simplifies U.S. Army environmental laws for the commander.
 - c. Includes Federal and State laws aimed at protecting our environment.
 - d. Helps the commander to understand environmental obligations and highlights requirements of laws and regulations.
 - e. b and d.

10. How should you dispose of garbage in the field?
- a. Burial.
 - b. Burning.
 - c. Shredding.
 - d. a or b.
11. Garbage should be buried in pits or trenches if the unit is:
- a. On the march.
 - b. On bivouac.
 - c. In camps of less than 1 week's duration.
 - d. Any of the above.
12. When burying garbage, why is it important to compact the earth?
- a. To save space.
 - b. To keep the enemy from seeing it.
 - c. So the water will drain.
 - d. To keep flies and rodents from the garbage.
13. When is the burial area sprayed?
- a. Before each dump.
 - b. After each dump.
 - c. After each second dump.
 - d. a and c above.

14. Which method of waste disposal is considered to be better and should be used whenever possible?
- a. Burial.
 - b. Incineration.
 - c. Grating.
 - d. Chopping.
15. Before garbage is burned, it should be:
- a. Separated or segregated.
 - b. Reduced in volume.
 - c. Packed.
 - d. Sprayed with an insecticide.
16. For incineration, solid garbage must be separated from liquid garbage by:
- a. Hand.
 - b. Straining it with a coarse strainer such as an old bucket, salvaged can, or 55-gallon drum.
 - c. Grating it.
 - d. Placing it in large holes.
17. In a barrel filter grease trap, the burlap fastened to the top of the drum serves as a:
- a. Barrier to flies.
 - b. Coarse strainer.
 - c. Rain cover.
 - d. Final filter.

18. Field filters should be:
- a. Made out of cardboard boxes.
 - b. Filled with rocks, crushed cans, sticks, or grass.
 - c. Covered with a screen.
 - d. b and c.
 - e. a, b, and c.
19. Field incinerators should be located:
- a. At least 70 yards from any source of water used for drinking.
 - b. No closer than 50 yards to a kitchen.
 - c. No further than 50 yards from the food service area.
 - d. At least 50 yards downwind from the camp.
20. If a 55-gallon drum is used to strain garbage before burning, where should the holes be punched?
- a. Top.
 - b. Side.
 - c. Bottom.
 - d. Everywhere except the top.
21. Pits or trenches should NOT be over _____ from the food service area.
- a. 30 yards.
 - b. 50 yards.
 - c. 60 feet.
 - d. 110 feet.

22. Garbage should NOT be buried closer than _____ from any source of water used for drinking or cooking?
- a. 10 yards.
 - b. 40 yards.
 - c. 80 feet.
 - d. 100 feet.
23. What are the two types of incinerators used in the field?
- a. Barrel and drum.
 - b. Inclined plane incinerator and barrel.
 - c. Ditch and drum.
 - d. Helmet and inclined incinerator.
24. What is the simple rule for returning materials from the field to the installation?
- a. Use it or lose it.
 - b. If you brought it to the field, then bring it back.
 - c. Pile it up and leave it for the next soldier.
 - d. Burn it all.
25. All of the following is considered to be rubbish generated in the field EXCEPT:
- a. Wastepaper.
 - b. Empty wooden boxes.
 - c. Broken crockery.
 - d. Empty tin cans.
 - e. Left-over food.

26. Before liquid waste can be disposed in the field, what should be done to better allow the liquid to soak into the ground?
- Filter or remove food particles, soap, and grease (solvents) contained in this water.
 - Extend evacuated dirt.
 - Cover each dump.
 - Use clay soil to line the trench or pit.
27. If the ground is too hard or not permeable for soakage pits or trenches, what should you do with the liquid waste?
- Devise a new system.
 - Discard it.
 - Use evaporation beds.
 - Boil it.
28. In a temporary camp, a soakage pit of 4 feet square and 4 feet deep normally will be adequate for the disposal of liquid kitchen waste for how many soldiers?
- 100
 - 200.
 - 300.
 - 400.
29. How many soakage pits are needed if the unit remains in the field for 2 weeks?
- 1.
 - 2.
 - 3.
 - 4.

30. What should you do if the soakage pit becomes clogged?
- Unclog and continue to use it.
 - Construct another.
 - Use the other one while this one self cleans.
 - Cover it with one foot of compacted earth, mark it, and construct a new one.
31. Which statement is correct about a baffle grease trap?
- The drum or box is divided vertically into an entrance, three middle chambers, and an exit chamber by attaching a wooden baffle.
 - The baffle should hang to a point within one inch of the bottom.
 - A strainer may be made from glass, wood, or rock.
 - The grease trap must always be watertight and it can never be placed partially under the ground.
32. Which statement is out of sequence (comes too late) for the baffle grease trap process?
- The chambers are filled with cool water.
 - As the warm liquid strikes the cool water, the grease rises to the surface of the entrance chamber.
 - When the liquid reaches the outlet pipe near the top of the exit chamber, it runs through this pipe into the soakage pit.
 - The liquid runs under the baffle, filling the exit chamber.

33. Which statement is correct concerning the barrel filter grease trap?
- Six inches of gravel or small stones are placed in the bottom and covered with 12 to 18 inches of wood ashes or sand.
 - The drum's bottom is removed and a number of large holes bored.
 - If it is placed directly over the pit, the top may be removed instead of having holes bored in it.
 - The burlap filter should be either washed or replaced every day.
34. Where is the barrel filter grease trap normally placed when it is used for the soakage pit?
- Near the soakage pit.
 - On a platform with a trough leading to a soakage pit.
 - Directly over a soakage pit.
 - b and c.
35. From the list provided, what should be performed every 2 days to the barrel filter grease trap and its content?
- The grease trap should be emptied, washed, and refilled with fresh ashes or sand.
 - The barrel should be scrubbed down.
 - The old ashes or sand should be buried.
 - Alcohol should be poured on the burlap filter to sanitize it.
 - The burlap filter should be either washed or replaced every day.
- 1, 4, and 5.
 - 2, 3, and 5.
 - 1, 3, and 5.
 - 3, 4, and 5.

36. Why is it even more important to safely handle and dispose of regulated medical waste in the field than at the installation?

- a. There is an increase in the possibilities of personnel being exposed to regulated medical waste in a less standard and less sterile environment.
- b. There is a greater chance for standardization and a sterile environment.
- c. The risk is less for contacting an infection or regulated medical waste disease.
- d. All of the above.

37. What are potential sources of regulated medical waste?

- a. Pathological waste.
- b. Human blood and blood products.
- c. Used and unused sharps.
- d. All of the above.

38. What is the preferred method of disposal of regulated medical waste material in the field?

- a. Burial.
- b. Burial in a garbage pit.
- c. Burial in a garbage pit after it has been autoclaved.
- d. Incineration, then burial in a separate pit.

39. Nonmixable used and waste oils are considered hazardous materials because they contain:
- Oil and water, two nonmixing substances, which can be kept near a stream.
 - Halogenated solvents in excess of 1,000 parts per million (PPM).
 - Between 80 and 1,000 PPM halogenated solvents as a result of other than normal operations.
 - Halogenated solvents below 1,000 PPM, which may be blended or mixed with other Class II waste for storage prior to burning.
40. Class II field waste, stored prior to burning IAW 40 CFR 266, Subpart B, concerns:
- Ignitable, corrosive, reactive, and/or toxic materials.
 - Nonmixable used and waste oils.
 - Mixable POL waste.
 - Spilled oil.
41. With new environmental laws enacted, field maintenance of vehicles is limited. Which of the following is/are correct?
- No POL, grease, rags or toweling, and the like be dumped or spilled on the ground by soldiers.
 - All waste POL must be placed in drums and returned to garrison for recycling.
 - Vehicles will not be washed in or near any lake or stream.
 - All of the above.

42. What is to happen when oil spills occur in the field?
- Let it seep into the lake or stream.
 - Place sandbags around the oil or other material until it can be cleaned up.
 - Report the spill if over 40 gallons and contained to land.
 - All of the above.
43. As part of energy recovery, 40 CFR 261 and 266 are concerned with what type of field hazardous materials?
- Ignitable and corrosive waste.
 - Maintenance vehicle supply waste.
 - Spillage of fuels.
 - Nonmixable used and waste oils.
44. If soldiers are exposed to an environmental hazard and you PVNTMED personnel are requested, what are all of the sequenced actions or steps you should do, if applicable?
- Determine patient symptoms.
 - Make recommendations to the commander.
 - Perform risk assessment.
 - Follow evaluation procedures.
 - Survey the site.
- 1, 3, 4, 5, and 2.
 - 2, 4, 3, 1, and 5.
 - 1, 5, 3, 4, and 2.
 - 3, 2, 5, 1 and 4.

45. Who determines the cause of an outbreak of food poisoning?
- a. Commander.
 - b. DOL.
 - c. DRMO.
 - d. Preventive medicine personnel.
46. Who is the responsible person for officially receiving a request to investigate a possible environmental health hazard?
- a. Preventive medicine personnel.
 - b. DOL.
 - c. DRMO.
 - d. DLA.
47. Some warm food was served on a hot day in the field and several soldiers in the platoon complained about the food. What are their probable symptoms?
- a. Ear aches, dizziness, and clogged nostrils.
 - b. Fainting, morning sickness, and dizziness.
 - c. Nose bleed, lung damage, eye irritations, and coughing.
 - d. Fainting, diarrhea, fever, stomach aches, and cold sweats.
48. In surveying the field food site for possible clues, you take samples of all of the food served. Which of the following is most likely to have caused the symptoms experienced in exercise 47?
- a. Wilted celery.
 - b. Warm deviled eggs.
 - c. Dried out bagels.
 - d. Raisins.

49. You have the samples analyzed from exercise 48 and find that the cause was salmonellosis. What step is this?
- a. Perform a spy mission.
 - b. Make recommendations to the commander.
 - c. Perform risk assessment.
 - d. Follow evaluation procedures.
50. You evaluated the procedures followed and data collected (exercises 47 to 49), determined the potential or impact of the contamination, wrote your report, and recommended to the commander that:
- a. Deviled eggs will no longer be served in the field.
 - b. Soldiers have to wash their hands before they eat deviled eggs.
 - c. Deviled eggs are always hazardous to soldiers.
 - d. Deviled eggs must be kept at a certain temperature until served and eaten within a prescribed time as per recipe specifications.

Check Your Answers on Next Page

SOLUTIONS TO EXERCISES, LESSON 2

1. b (para 2-1)
2. d (para 2-2)
3. a (para 2-2)
4. c (para 2-2)
5. c (para 2-2a)
6. b (para2- 2b)
7. b (para 2-3a(1))
8. a (para 2-3a(2))
9. e (para 2-3b)
10. d (para 2-5)
11. d (para 2-5a(1))
12. d (para 2-5a(1))
13. b (para 2-5a(1))
14. a (para 2-5b(1))
15. a (para 2-5b(2))
16. b (para 2-5b(2))
17. b (para 2-5b(2), figure 2-1)
18. d (para 2-5b(2))
19. d (para 2-5b(2))
20. c (para 2-5b(2))
21. a (para 2-5a(3))
22. d (para 2-5a(3))

23. b (para 2-5b, figures 2-1, 2-2)
24. b (para 2-6)
25. e (para 2-6)
26. a (para 2-7)
27. c (para 2-7)
28. b (para 2-7a (1))
29. b (para 2-7a(1))
30. d (para 2-7a(1))
31. b (para 2-7b(1))
32. d (para 2-7b(1)(a))
33. d (para 2-7b(2))
34. d (para 2-7b(2))
35. c (para 2-7b(2))
36. a (para 2-8a)
37. d (para 2-8a)
38. d (para 2-8b)
39. b (para 2-10c(2))
40. c (para 2-10c(3))
41. d (para 2-10c(5))
42. b (para 2-10c(4))
43. d (para 2-10c(2))
44. c (para 2-11)
45. d (para 2-11)

- 46. a (para 2-11)
- 47. d (para 2-11a)
- 48. b (para 2-11b)
- 49. c (para 2-11c)
- 50. d (para 2-11e)

End of Lesson 2

COMMENT SHEET

SUBCOURSE MD0162 Solid Waste Disposal

EDITION 100

Your comments about this subcourse are valuable and aid the writers in refining the subcourse and making it more usable. Please enter your comments in the space provided. ENCLOSE THIS FORM (OR A COPY) WITH YOUR ANSWER SHEET **ONLY** IF YOU HAVE COMMENTS ABOUT THIS SUBCOURSE..

FOR A WRITTEN REPLY, WRITE A SEPARATE LETTER AND INCLUDE SOCIAL SECURITY NUMBER, RETURN ADDRESS (and e-mail address, if possible), SUBCOURSE NUMBER AND EDITION, AND PARAGRAPH/EXERCISE/EXAMINATION ITEM NUMBER.

PLEASE COMPLETE THE FOLLOWING ITEMS:

(Use the reverse side of this sheet, if necessary.)

1. List any terms that were not defined properly.

2. List any errors.

paragraph error correction

3. List any suggestions you have to improve this subcourse.

4. Student Information (optional)

Name/Rank _____

SSN _____

Address _____

E-mail Address _____

Telephone number (DSN) _____

MOS/AOC _____

PRIVACY ACT STATEMENT (AUTHORITY: 10USC3012(B) AND (G))

PURPOSE: To provide Army Correspondence Course Program students a means to submit inquiries and comments.

USES: To locate and make necessary change to student records.

DISCLOSURE: VOLUNTARY. Failure to submit SSN will prevent subcourse authors at service school from accessing student records and responding to inquiries requiring such follow-ups.